

# ASSEMBLY INSTRUCTIONS NOTICE D'ASSEMBLAGE

ITEM: HF250081/REE47FIR

Important note/Note importante:

1. Place all wooden parts on a clean and smooth surface such as a rug or carpet to avoid scratching the parts./Placer les pièces sur une surface propre et lisse tel qu'une couverture ou un tapis pour éviter d'endommager les pièces.

2. Kindly follow the assembly instructions step by step./Veuillez suivre la notice d'assemblage, pas à pas.

3. Check to ensure this carton contains all parts./Vérifiez le contenu de cet emballage pour vous assurer qu'il contienne toutes les pièces.

## PARTS IDENTIFICATION / IDENTIFICATION DES PIÈCES



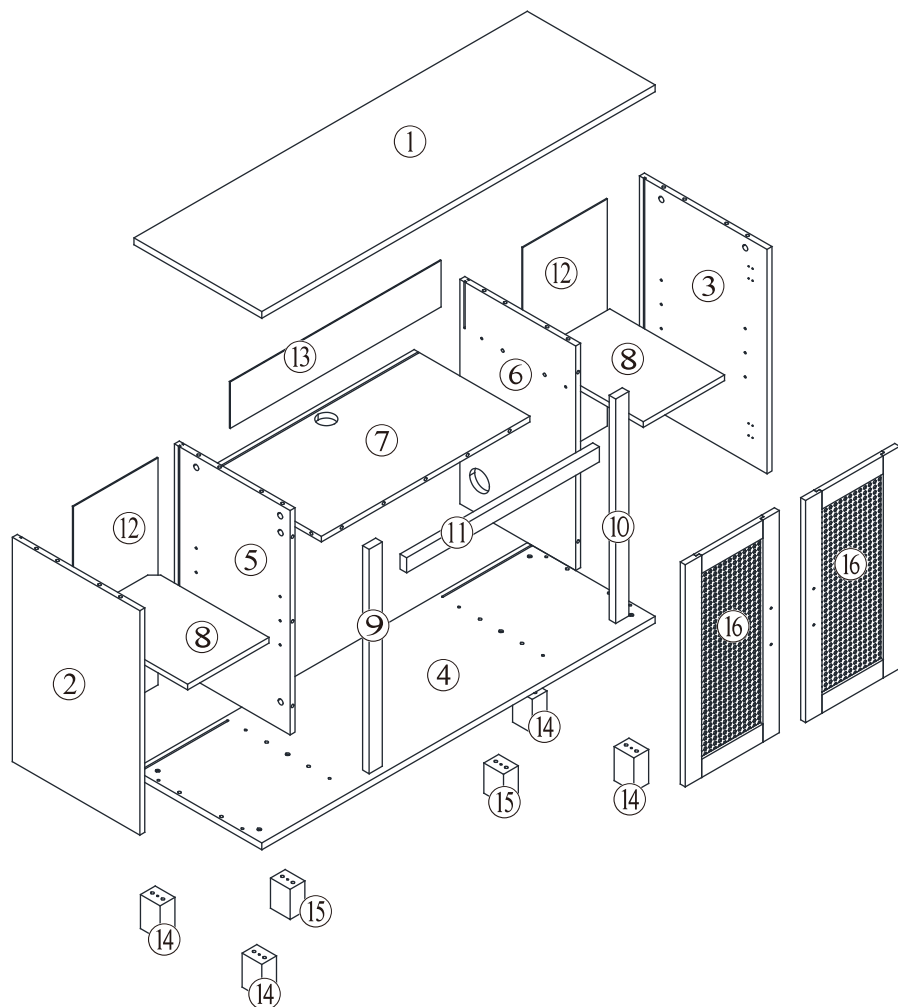















- ① x 1pc/pce
- ② x 1pc/pce
- ③ x 1pc/pce
- ④ x 1pc/pce
- ⑤ x 1pc/pce
- ⑥ x 1pc/pce
- ⑦ x 1pc/pce
- ⑧ x 2pcs/pces
- ⑨ x 1pc/pce
- ⑩ x 1pc/pce
- ⑪ x 1pc/pce
- ⑫ x 2pcs/pces
- ⑬ x 1pc/pce
- ⑭ x 4pcs/pces
- ⑮ x 2pcs/pces
- ⑯ x 2pcs/pces



# ASSEMBLY INSTRUCTIONS NOTICE D'ASSEMBLAGE

ITEM: HF250081/REE47FIR

## HARDWARE IDENTIFICATION / IDENTIFICATION DES PIÈCES MONTAGE

A		$\Phi 7.2 \times 36.3 \text{mm}$	19 pcs/pces
B		$\Phi 15 \times 10 \text{mm}$	19 pcs/pces
C		$\Phi 7.8 \times 30 \text{mm}$	36 pcs/pces
D		$\Phi 5 \times 50 \text{mm}$	14 pcs/pces
E		$\Phi 4 \times 35 \text{mm}$	2 pcs/pces
F		$\Phi 4 \times 14 \text{mm}$	24 pcs/pces
G			4 pcs/pces
H		$\Phi 6 \times 30 \text{mm}$	2 pcs/pces
I		$\Phi 4 \times 20 \text{mm}$	2 pcs/pces
J		$200 \times 32 \times 1.5 \text{mm}$	2 pcs/pces
K		$\Phi 12 \times \Phi 6.2 \times 1 \text{mm}$	4 pcs/pces
L		$M4 \times 18 \text{mm}$	4 pcs/pces
M			2 pcs/pces
N			8 pcs/pces
O		$\Phi 3 \times 16 \text{mm}$	8 pcs/pces
P		$\Phi 5 \times 25 \text{mm}$	8 pcs/pces
Q			2 pcs/pces
EE		$\Phi 3 \times 12 \text{mm}$	4 pcs/pces+ extra 1 pc/pce

# ASSEMBLY INSTRUCTIONS NOTICE D'ASSEMBLAGE

## Necessary tools/Outils nécessaires



Glue not included ( We recommend to apply some glue into holes before inserting wood dowels .)

Colle non inclus (Nous vous recommandons d'appliquer quelques gouttes de colle dans les trous avant d'introduire les chevilles de bois.)

## How to use cam lock system/Comment utiliser le système de verrouillage

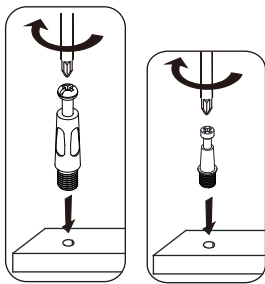

\*Screw in cam post and tighten in place.

\*Visser le montant de came et serrer en place.

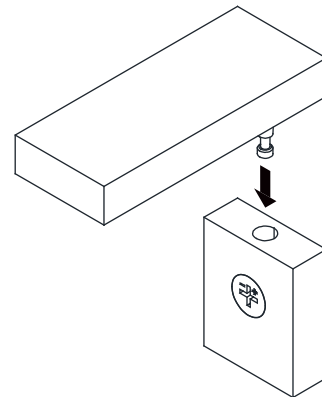
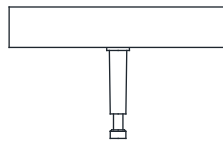

\*Ensure that the cam lock arrow is pointed to the hole, align the cam lock screw to the hole of the cam lock case.

\*Assurez-vous que la flèche de verrouillage sur l'écrou de sécurité est orientée vers l'orifice, insérez la vis de verrouillage dans l'orifice.

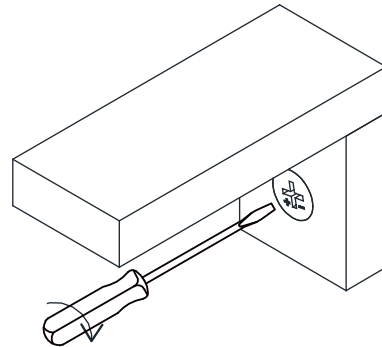
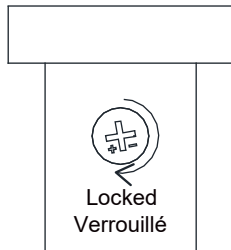

\*Use a straight edge screwdriver to turn cam lock case until it is locked. Locked position is approximately 1/2 turn (210°) clock-wise.

\*Utilisez un tournevis ligne droite pour faire tourner l'écrou de sécurité afin de le verrouiller. La position verrouillée est environ 1/2 tour (210°) à la droite.

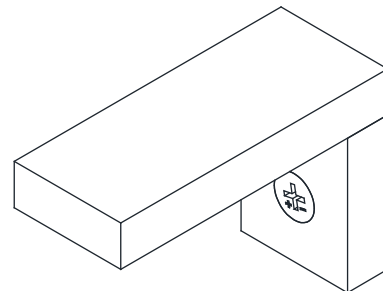
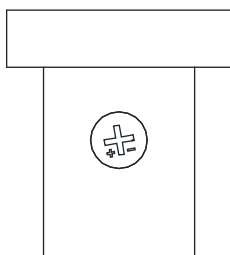

\*After turning the cam lock case to the locked position, the cam lock arrow will be located in the position shown above.

\*Après avoir tourné l'écrou de sécurité pour le verrouiller, la flèche de serrure de came se situeront dans la position indiquée ci-dessus.

# ASSEMBLY INSTRUCTIONS NOTICE D'ASSEMBLAGE

ITEM: HF250081/REE47FIR

## STEP 1 / ÉTAPE 1



A x 8



B x 4

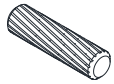

C x 2

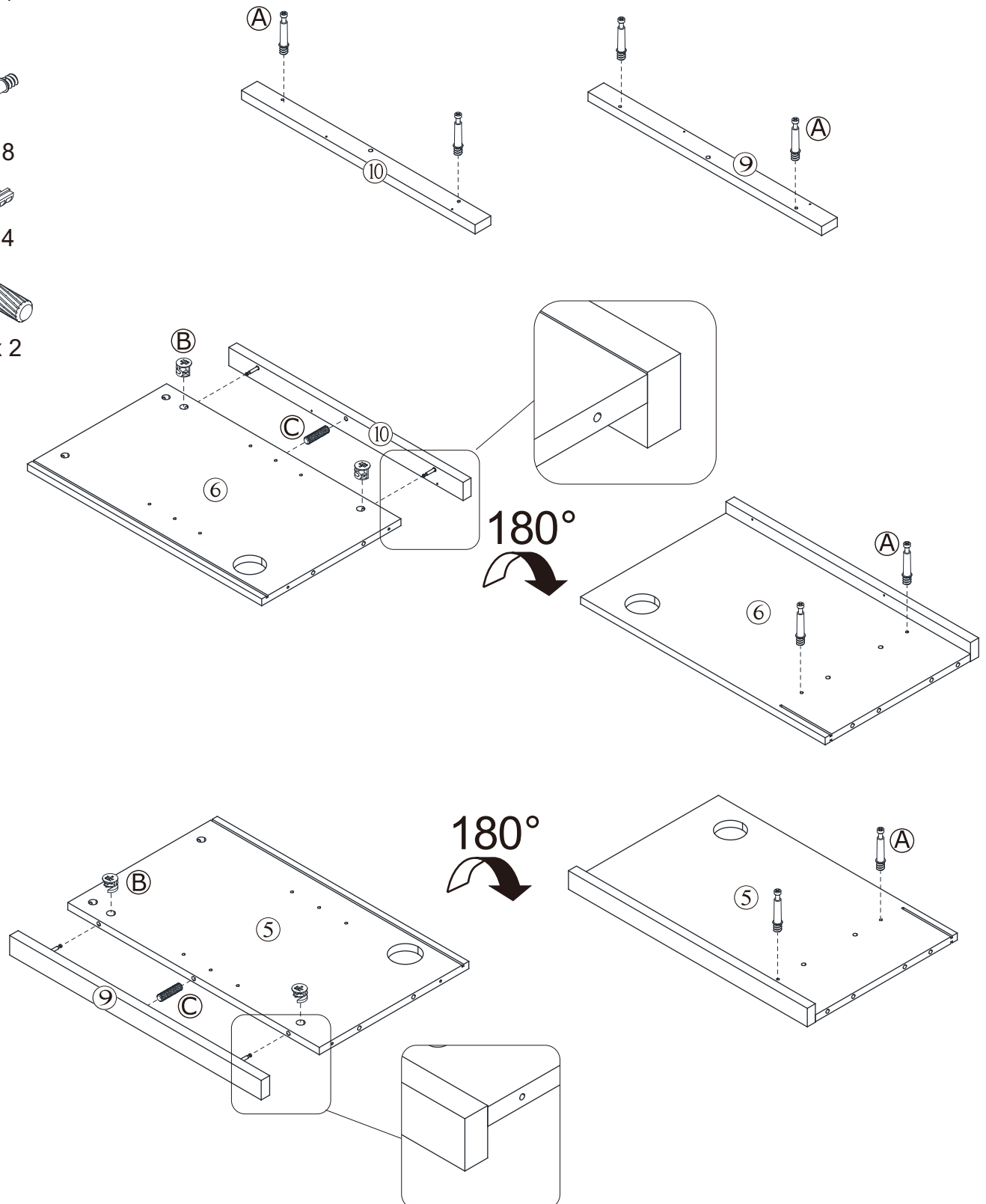

# ASSEMBLY INSTRUCTIONS NOTICE D'ASSEMBLAGE

ITEM: HF250081/REE47FIR

## STEP 2 / ÉTAPE 2



A x 3



B x 7

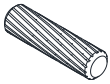

C x 6

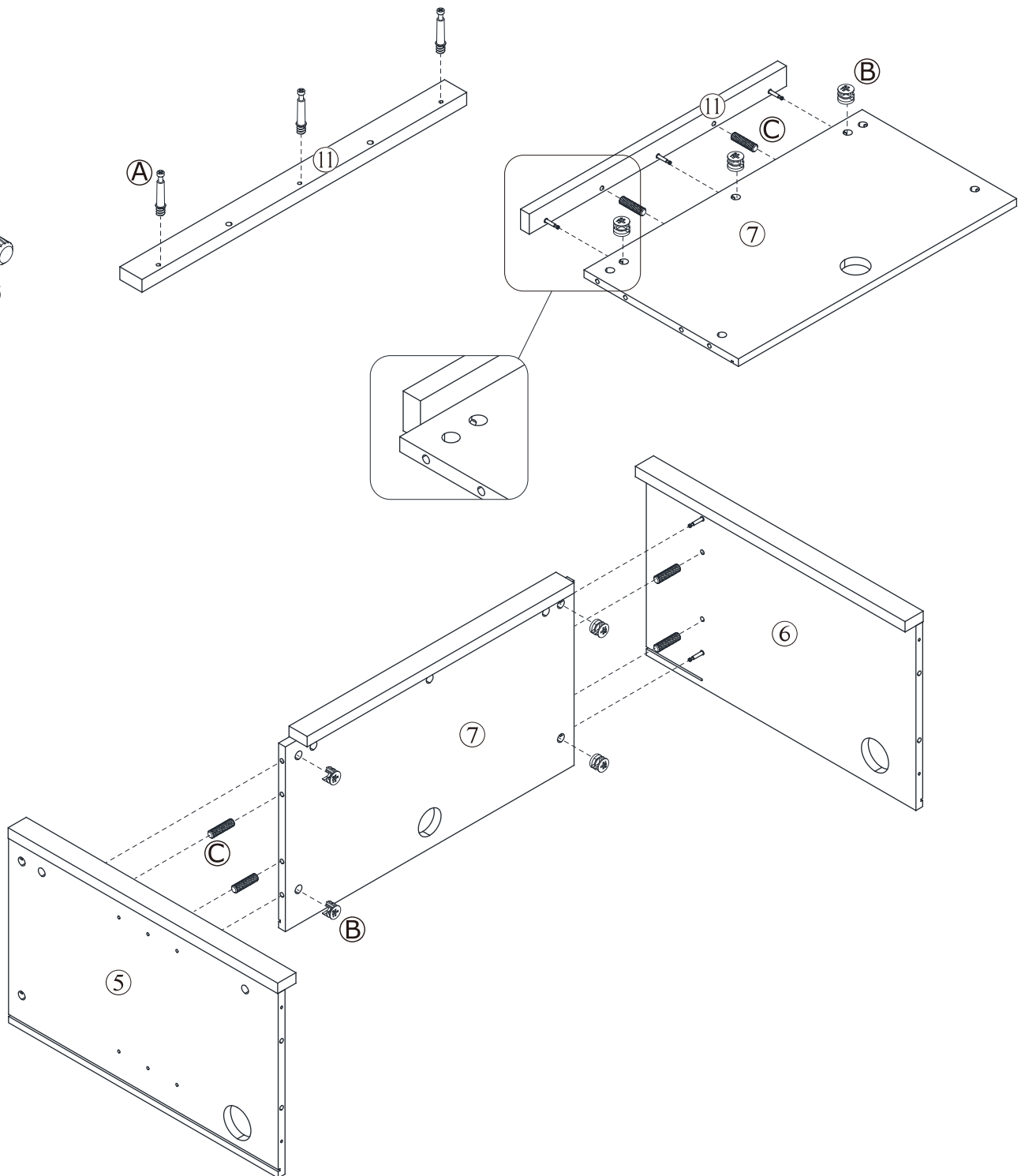

# ASSEMBLY INSTRUCTIONS NOTICE D'ASSEMBLAGE

ITEM: HF250081/REE47FIR

## STEP 3 / ÉTAPE 3

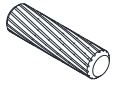

C x 8

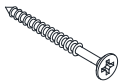

D x 6



Q x 2

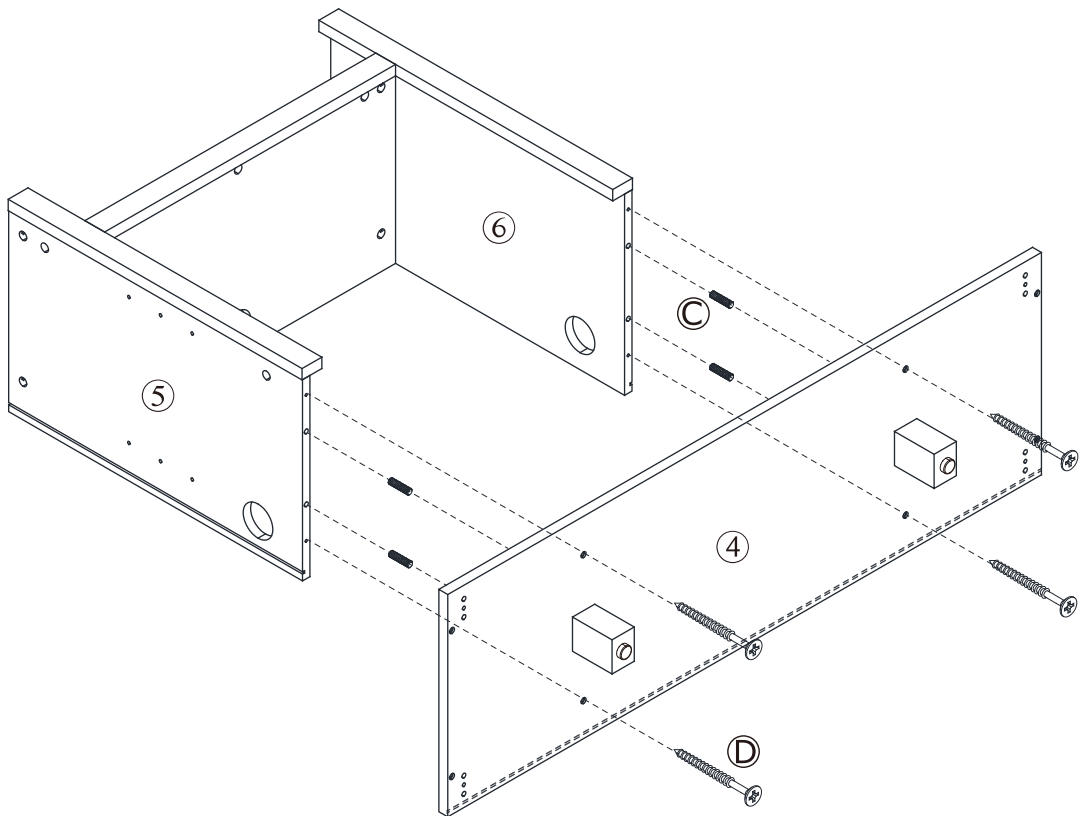
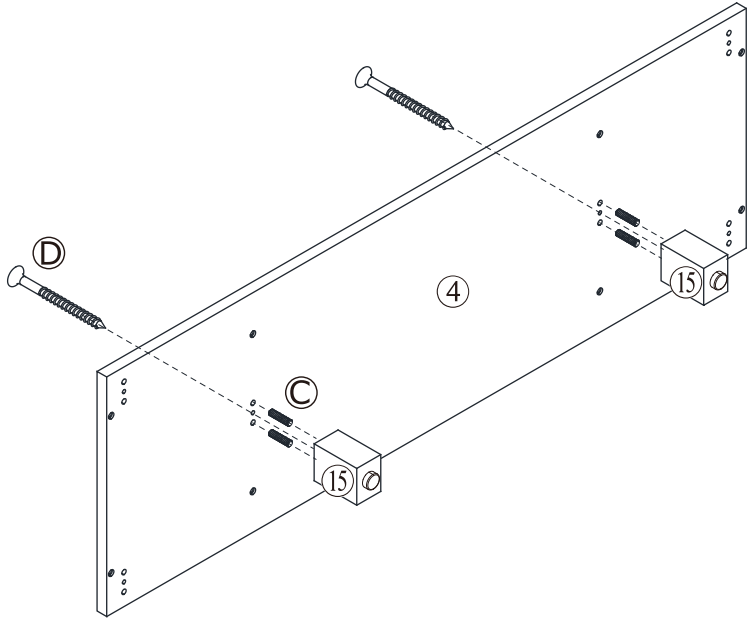
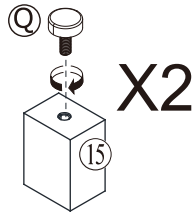

# ASSEMBLY INSTRUCTIONS NOTICE D'ASSEMBLAGE

ITEM: HF250081/REE47FIR

## STEP 4 / ÉTAPE 4

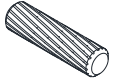

C x 12

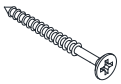

D x 8

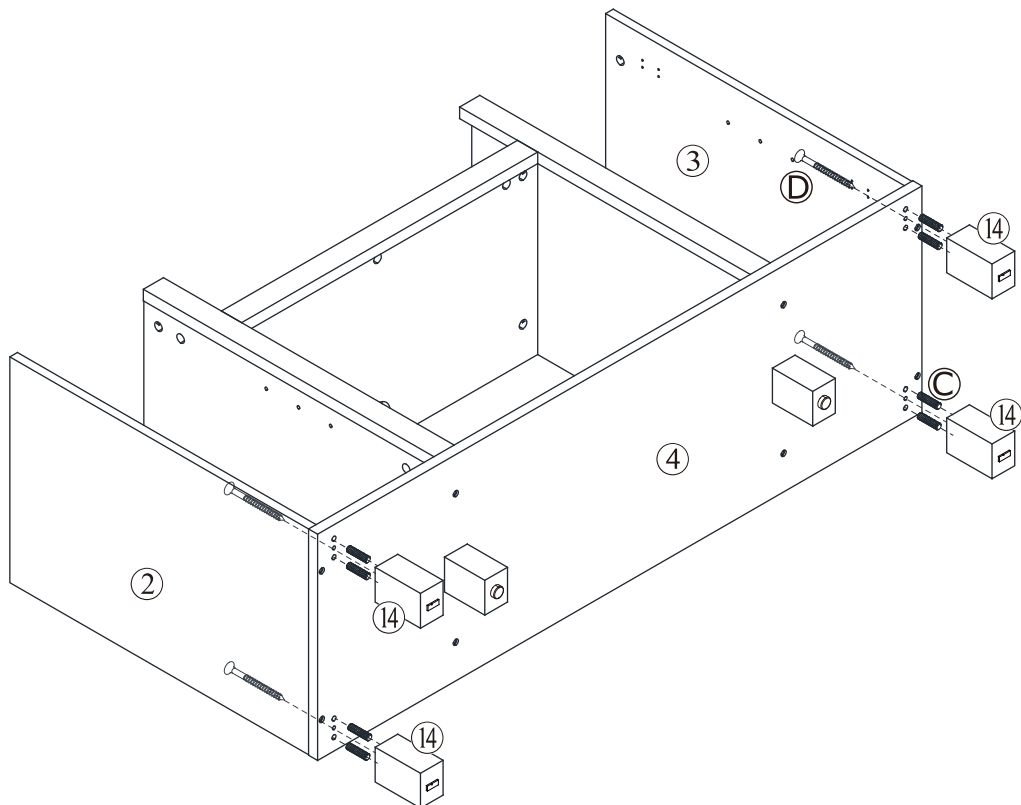
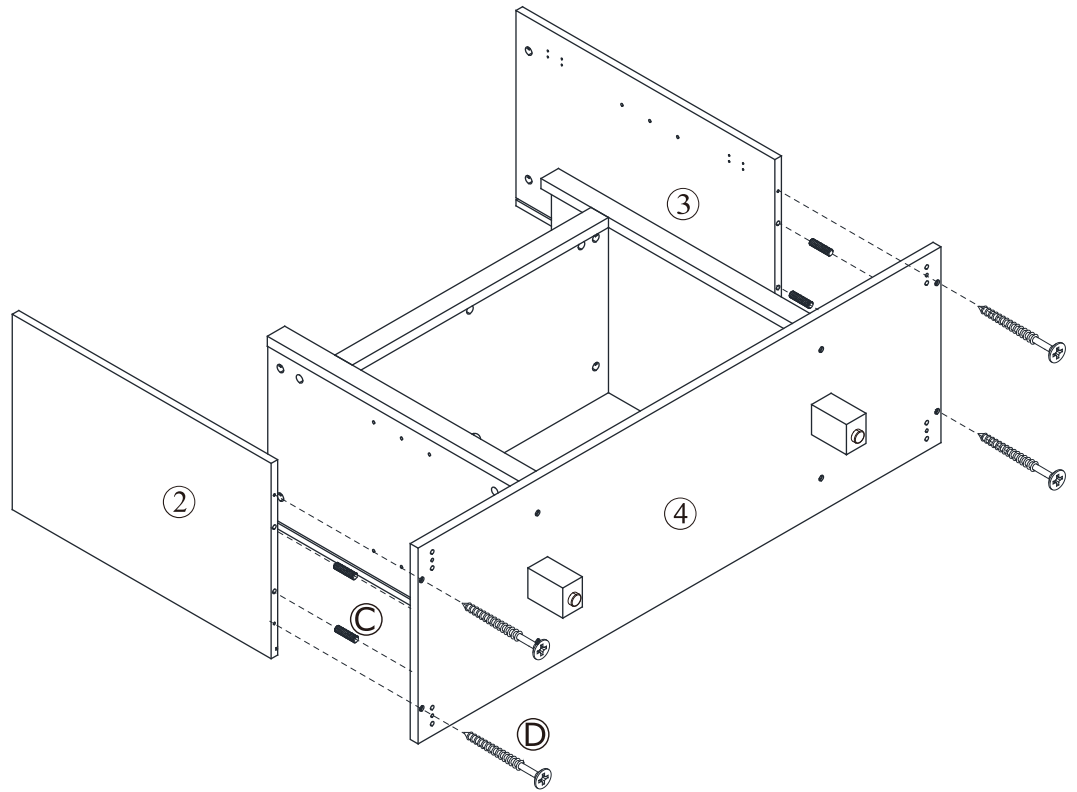

# ASSEMBLY INSTRUCTIONS NOTICE D'ASSEMBLAGE

ITEM: HF250081/REE47FIR

## STEP 5 / ÉTAPE 5



A x 8

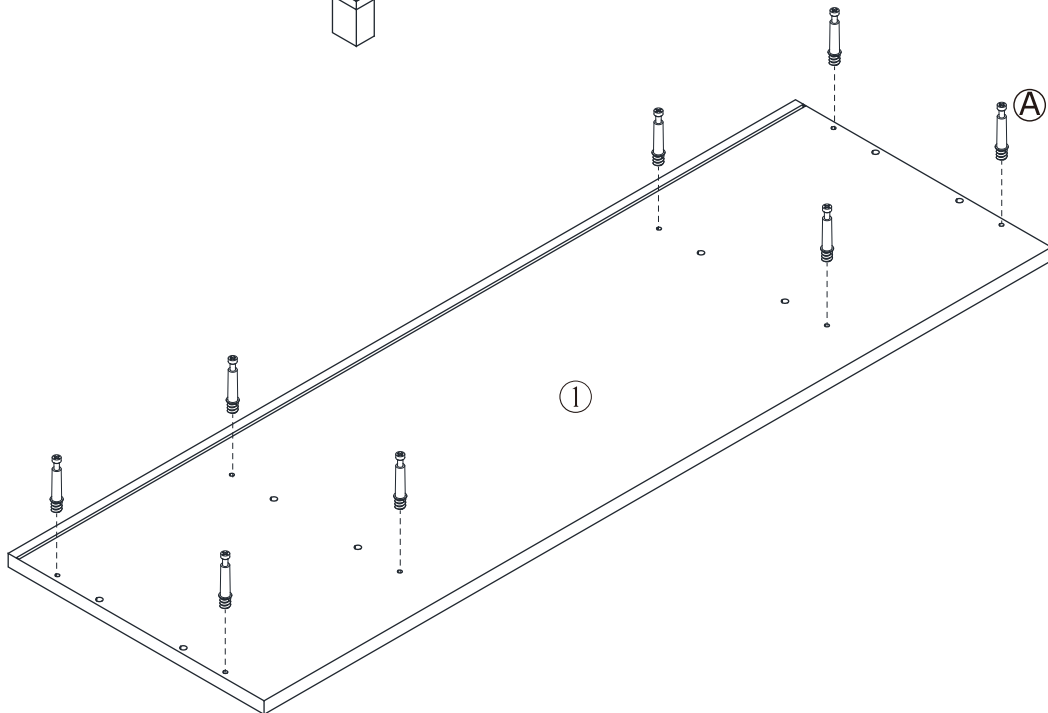
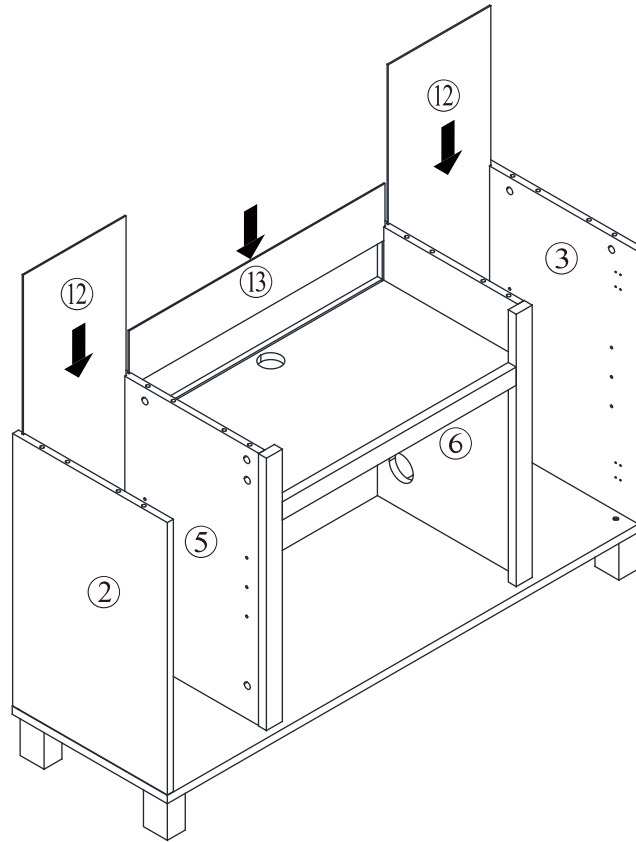

# ASSEMBLY INSTRUCTIONS NOTICE D'ASSEMBLAGE

ITEM: HF250081/REE47FIR

## STEP 6 / ÉTAPE 6



B x 8



C x 8



P x 8

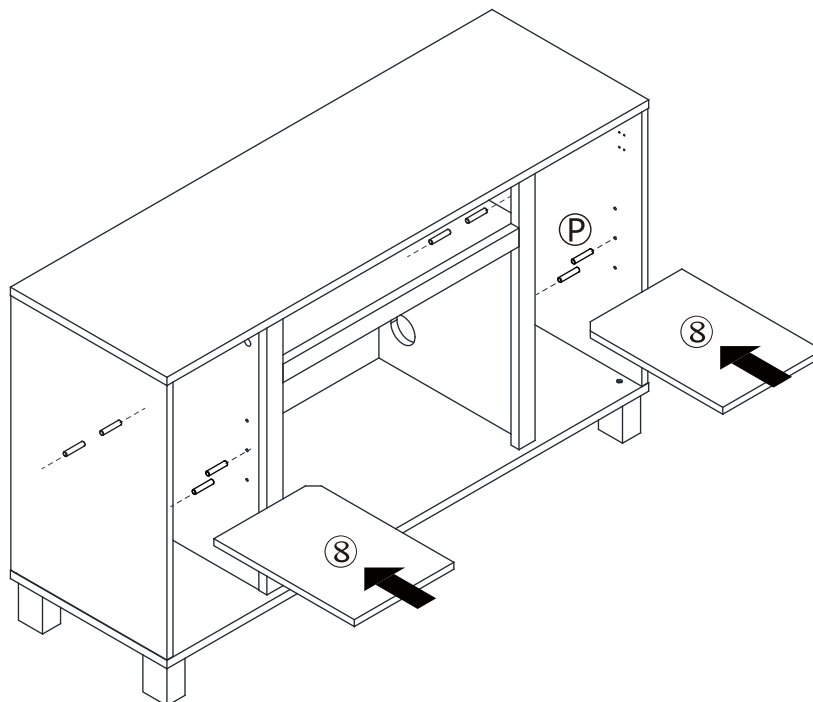
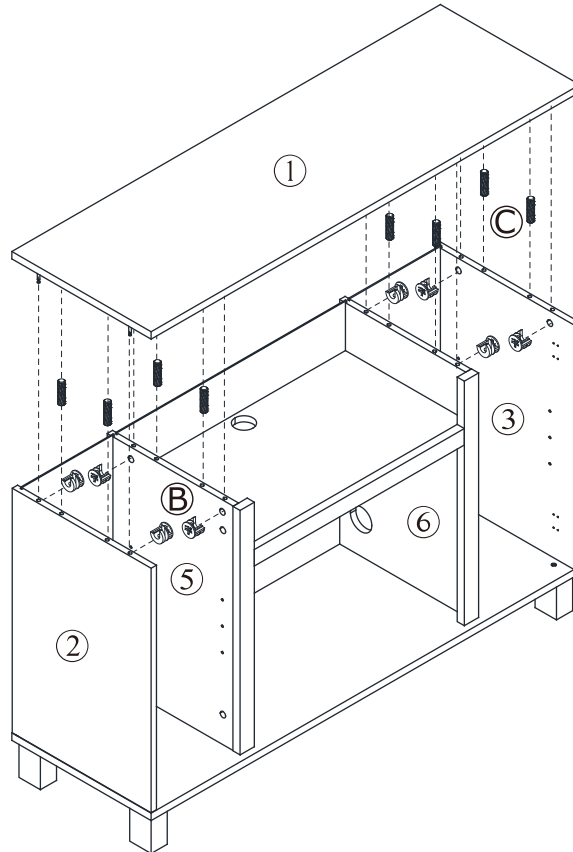

# ASSEMBLY INSTRUCTIONS NOTICE D'ASSEMBLAGE

ITEM: HF250081/REE47FIR

## STEP 7 / ÉTAPE 7

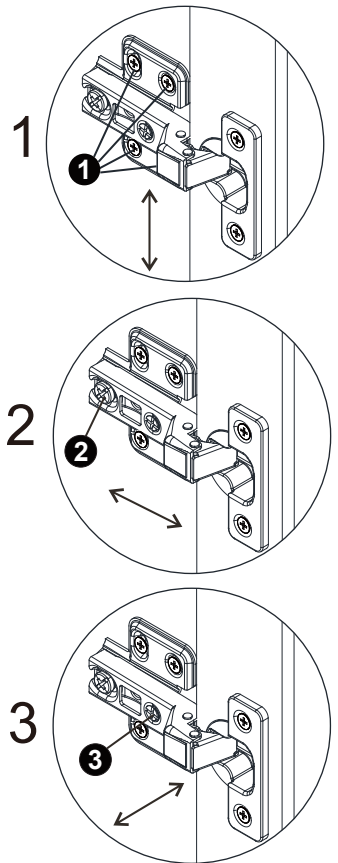
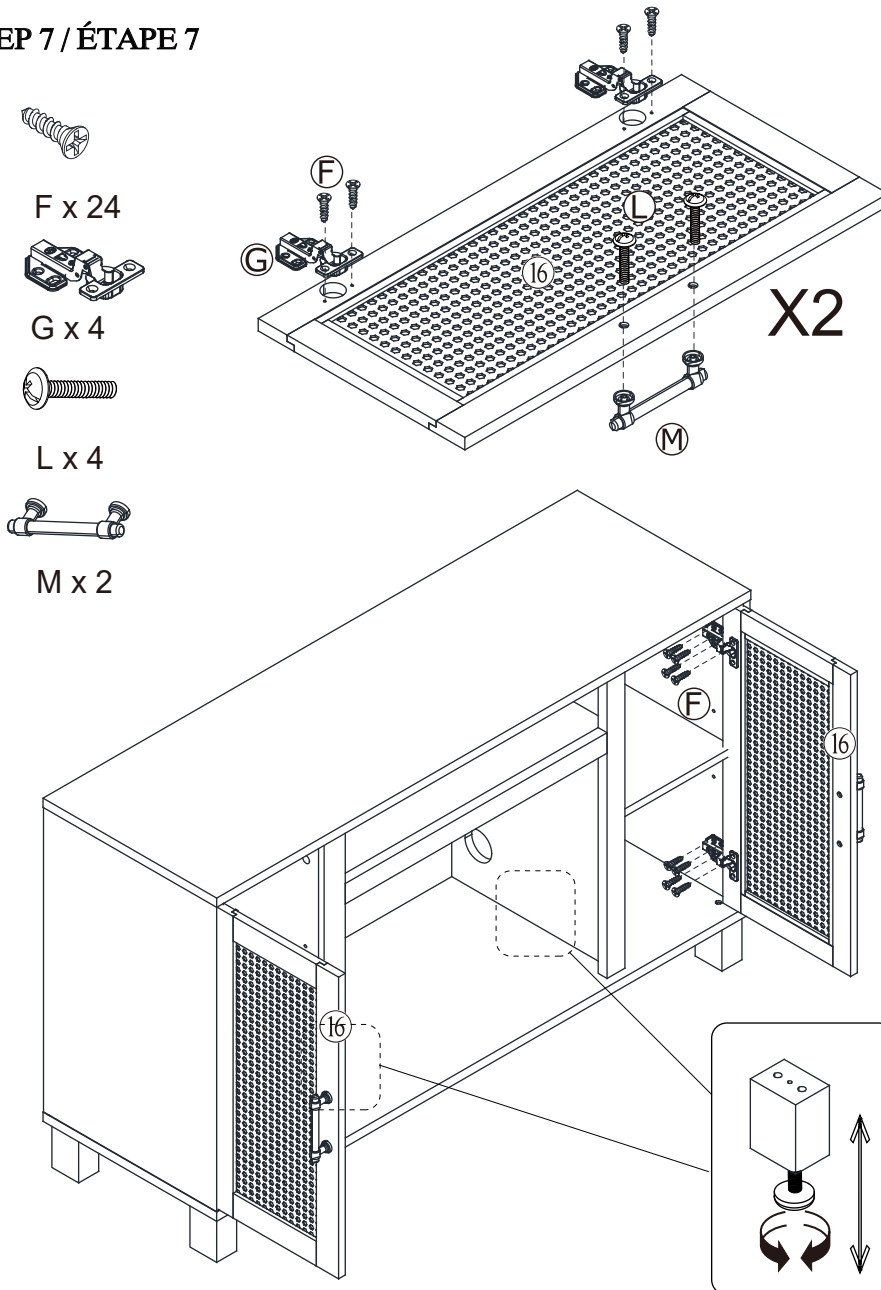

**WARNING:** Open and close the doors to make sure they are aligned and shut correctly. If necessary, adjust the screws and bolts for a good fit.

Figure 1: Adjust these 4 screws to adjust the up and down direction of the door.

Figure 2: Adjust the bolt to adjust the front and rear direction of the door.

Figure 3: Adjust the bolt to adjust the left and right direction of the door.

**AVERTISSEMENT :** Ouvrez et fermez les portes pour vous assurer qu'elles sont alignées et fermées correctement. Si nécessaire, ajustez les vis et les boulons pour obtenir un bon ajustement.

Figure 1 : Ajustez ces 4 vis pour ajuster la direction de haut et en bas de la porte.

Figure 2 : Ajustez le boulon pour ajuster la direction avant et arrière de la porte.

Figure 3 : Ajustez le boulon pour ajuster la direction gauche et droite de la porte.

# ASSEMBLY INSTRUCTIONS NOTICE D'ASSEMBLAGE

ITEM: HF250081/REE47FIR

## STEP 8 / ÉTAPE 8



N x 8



O x 8

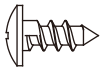



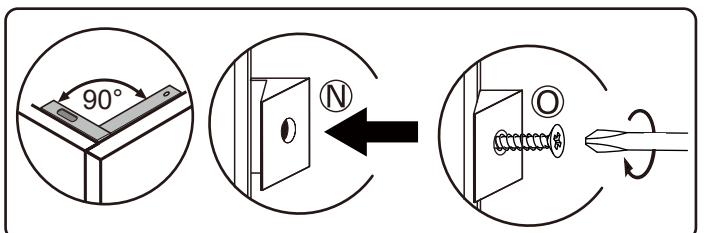
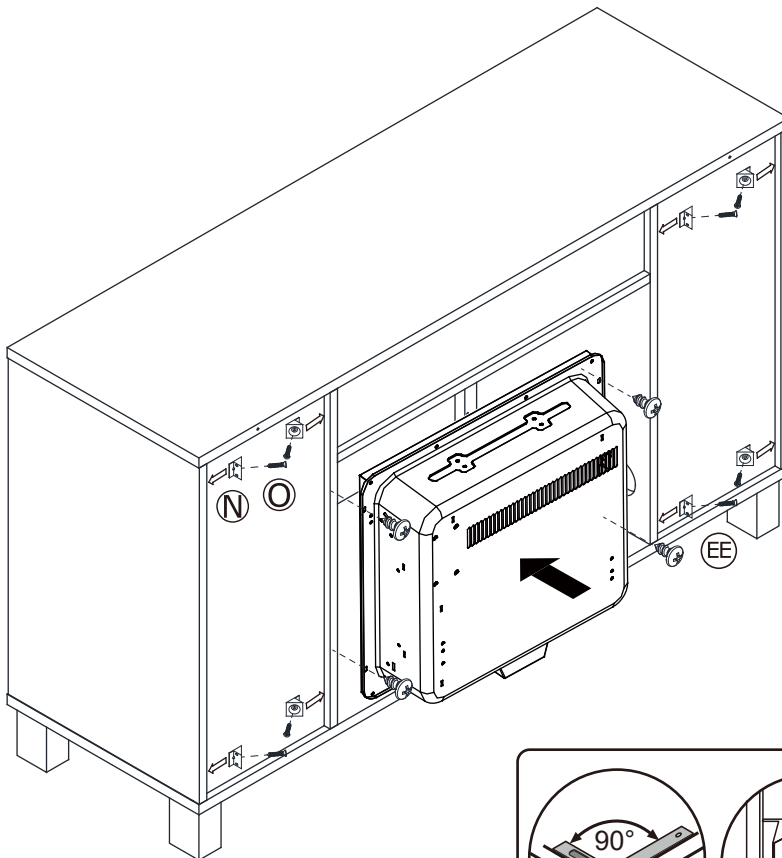
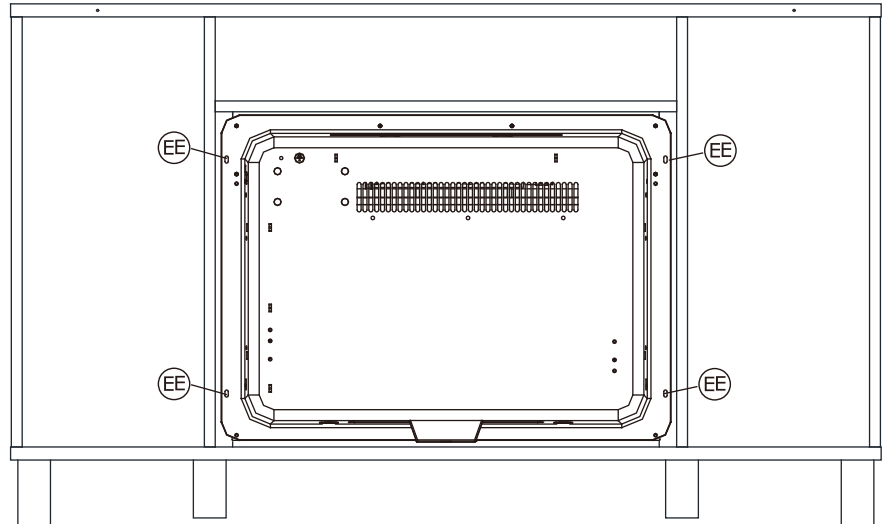

EE x 4



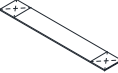

# ANTI-TIPPING STRIP INSTRUCTION

## INSTRUCTIONS POUR SANGLE ANTI-BASCULEMENT

### HARDWARE INCLUDED MATÉRIEL INCLUS

	SCREW VIS	Φ4×35mm	2 pcs/pces
	WALL ANCHOR ANCRE AU MUR	Φ6×30mm	2 pcs/pces
	SCREW VIS	Φ4×20mm	2 pcs/pces
	ANTI-TIP STRIP DISPOSITIF ANTI BASCULEMENT	200×32×1.5mm	2 pcs/pces
	FLAT WASHER RONDELLE PLATE	Φ12×Φ6.2×1mm	4 pcs/pces

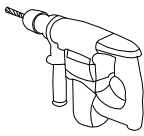
### TOOLS REQUIRED (NOT INCLUDED) OUTILS REQUIS (NON COMPRIS)

	DRILL & DRILL BIT PERCEUSE ET TRÉPAN
	LIGHT HAMMER MARTEAU LÉGER

Note : Hardware included only compatible with standard drywalls.  
 Notez: Que la quincaillerie incluse est compatible avec les ancrages de mur standard.

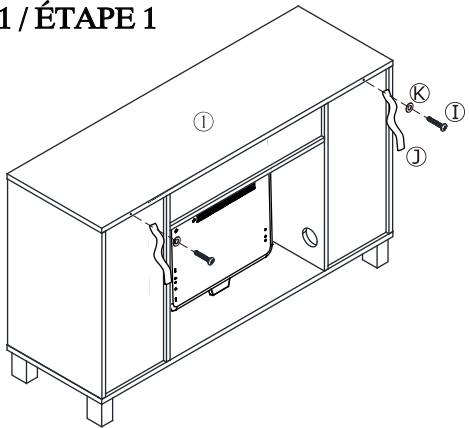
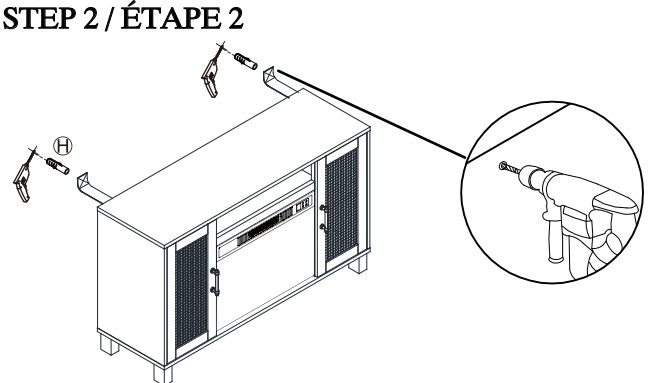
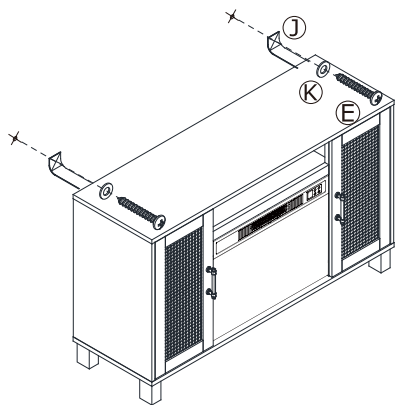
<p><b>STEP 1 / ÉTAPE 1</b></p>  <p>Attach the Anti-tip Strip (J) by inserting the Screw (I) through the Flat Washer (K) to the back top rail of the mantel.          Fixez la Dispositif Anti basculement (J) en insérant la Vis (I) à travers la Rondelle plate (K) sur le rail arrière du meuble.</p>	<p><b>STEP 2 / ÉTAPE 2</b></p>  <p>1. Find spot on wall 1" below the top of item. Placer sur le mur à 1 pouce au-dessus de l'article.          2. Using a drill bit slightly smaller than the gauge of Wall Anchor (H), drill a hole then place the Wall Anchor (H) into wall. A l'aide d'un trépan légèrement plus petit qu'un Ancre au mur insérée (H) en acier de jauge, percer un trou puis placer l'Ancre au mur insérée (H).</p>
<p><b>STEP 3 / ÉTAPE 3</b></p>  <p>Attach the other end of Anti-tip Strip (J) by insert the Screw (E) through the Flat Washer (K) to the inserted Wall Anchor (H).          Fixez l'autre extrémité de la Dispositif Anti basculement (J) en insérant la Vis (E) à travers la Rondelle plate (K) sur l'Ancre au mur insérée (H).</p>	

# ASSEMBLY INSTRUCTIONS NOTICE D'ASSEMBLAGE

ITEM: HF250081/REE47FIR

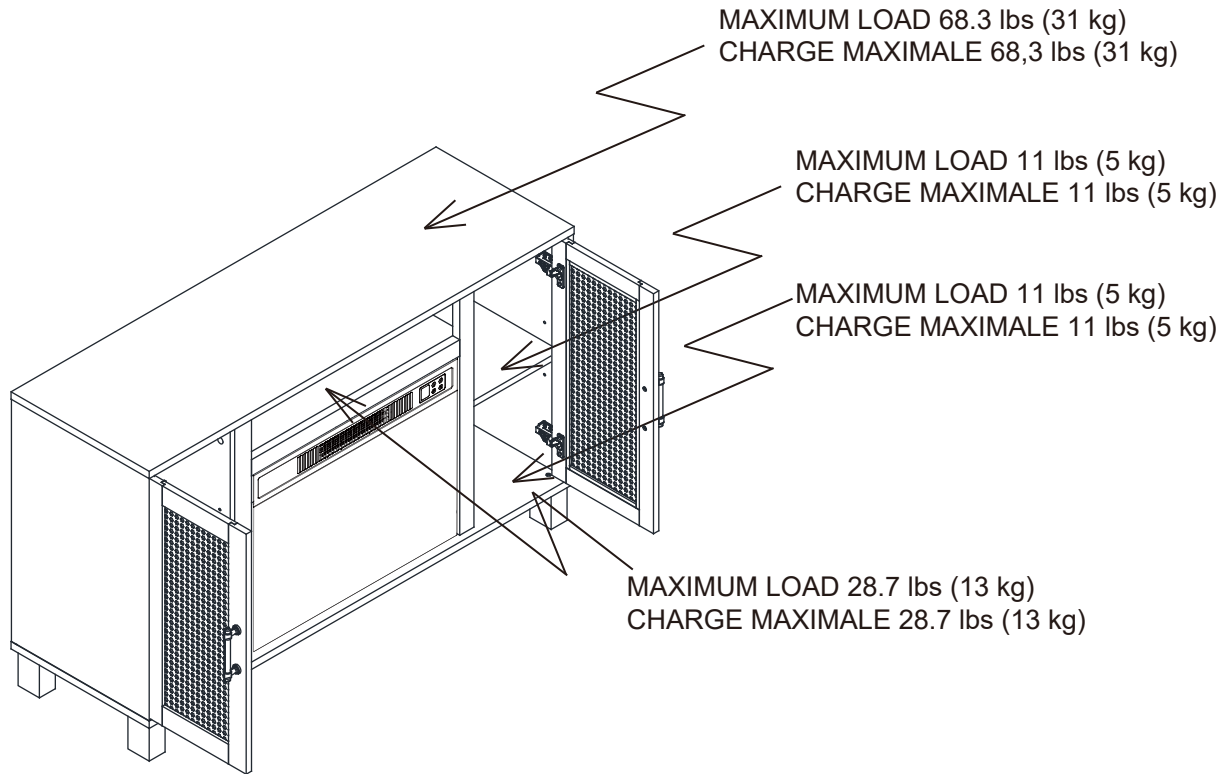

**COMPLETE / ASSEMBLAGE TERMINÉ**

