

ASSEMBLY INSTRUCTIONS / INSTRUCTIONS D'ASSEMBLAGE

ITEM NO/NO MAL72TVS: 192509

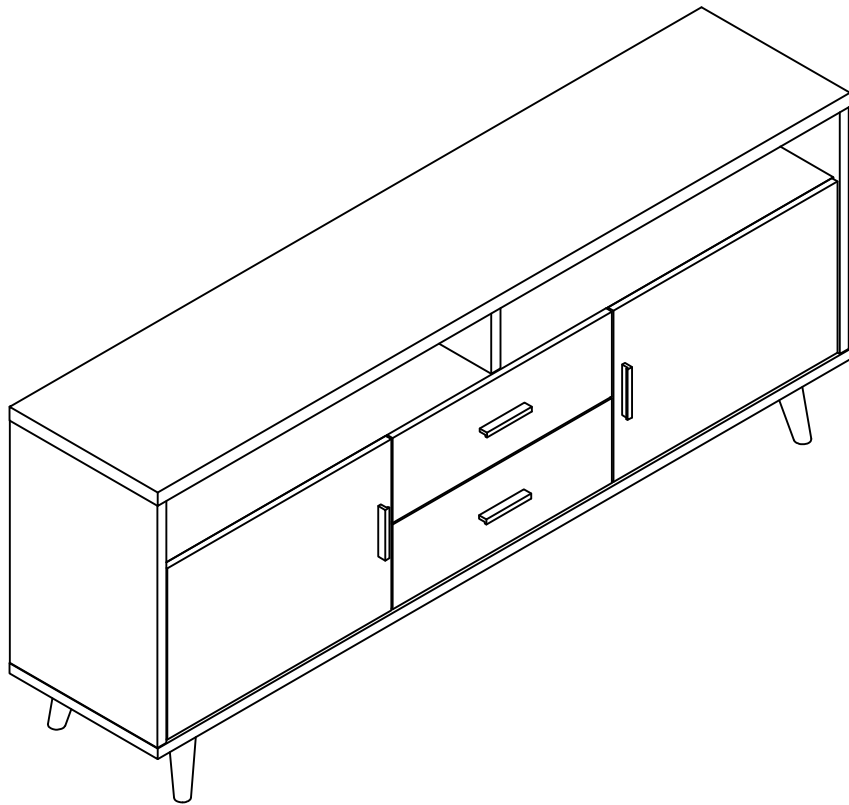

PARTS IDENTIFICATIONS / IDENTIFICATION DES PIECES



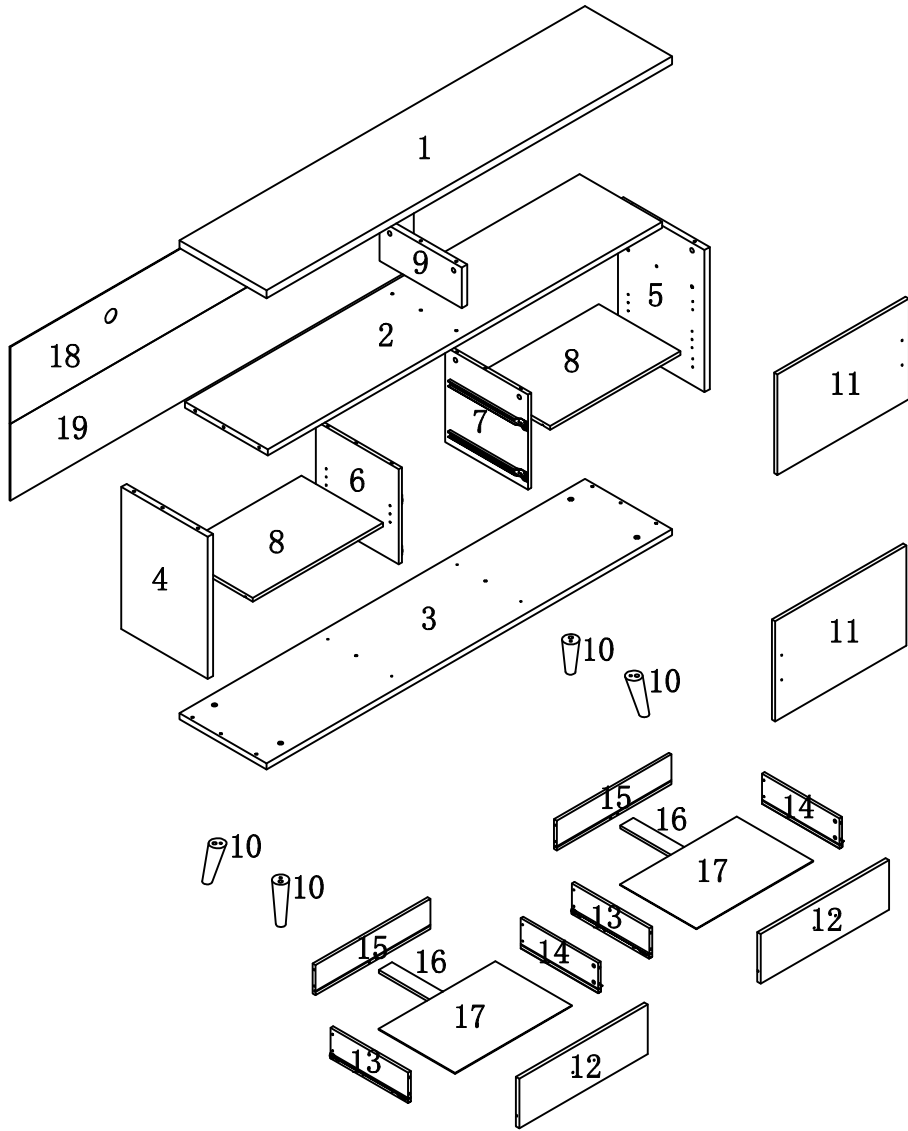









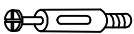







ITEM NO/NO MAL72TVS: 192509

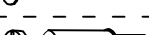

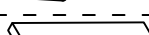
| | | | | | |
|-----|----------|------|----------|------|----------|
| (1) | 1pc/pce | (9) | 1pc/pce | (17) | 2pcs/pce |
| (2) | 1pc/pce | (10) | 4pcs/pce | (18) | 1pc/pce |
| (3) | 1pc/pce | (11) | 2pcs/pce | (19) | 1pc/pce |
| (4) | 1pc/pce | (12) | 2pcs/pce | | |
| (5) | 1pc/pce | (13) | 2pcs/pce | | |
| (6) | 1pc/pce | (14) | 2pcs/pce | | |
| (7) | 1pc/pce | (15) | 2pcs/pce | | |
| (8) | 2pcs/pce | (16) | 2pcs/pce | | |

HARDWARE IDENTIFICATIONS/ IDENTIFICATION DU KIT D'ASSEMBLAGE

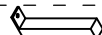
ITEM NO/NO MAL72TVS: 192509

| | | | |
|---|---|--|------------|
| A |  | M7x48 | 6pcs/pces |
| B |  | Φ 8x Φ 16x2 | 10pcs/pces |
| C |  | L29 | 14pcs/pces |
| D |  | Φ 15 | 14pcs/pces |
| E |  | Φ 8x25 | 16pcs/pces |
| F |  | Φ 22 | 10pcs/pces |
| G |  | Φ 4x40 | 4pcs/pces |
| H |  | M8x35 | 4pcs/pces |
| I |  | M5 | 1pc/pces |
| J |  | Φ 4x16 | 16pcs/pces |
| K |  | M6x12 | 4pcs/pces |
| L |  | Φ 5x15 | 8pcs/pces |
| M |  | Φ 4x30 | 12pcs/pces |
| N |  | L20 | 8pcs/pces |
| O |  | Φ 12 | 8pcs/pces |
| P |  | Φ 6x30 | 4Ppcs/pces |
| Q |  | 96# | 4pcs/pces |
| R |  | Φ 4x22 | 8pcs/pces |
| S |  | 301C | 4pcs/pces |
| T |  | | 55pcs/pces |
| U |  | 80x25x148 | 2pcs/pces |
| V |  | <p>Glue: For securing please apply to wood dowel first before inserting into panel. Colle: Appliquez de la colle sur les goujons en bois avant de les insérer dans le panneau.</p> | 1pc/pces |

ITEM NO/NO MAL72TVS: 192509

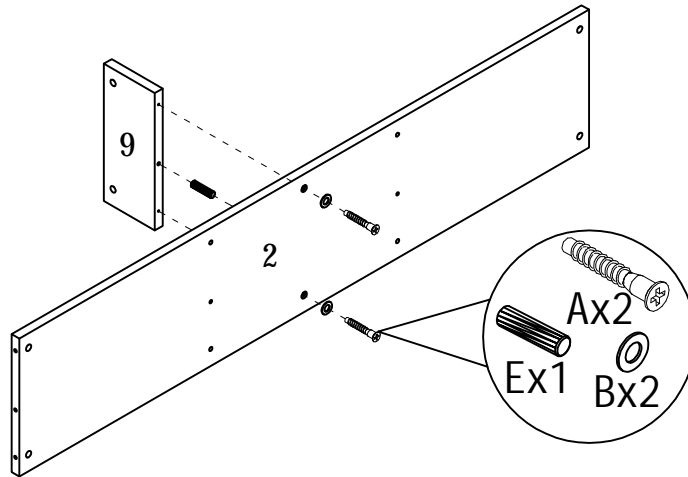

STEP 1 / ETAPE 1

STEP 2 / ETAPE 2

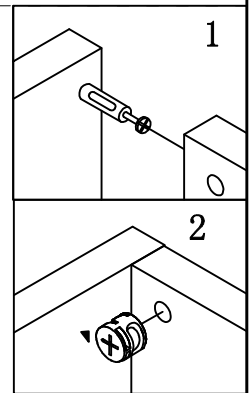
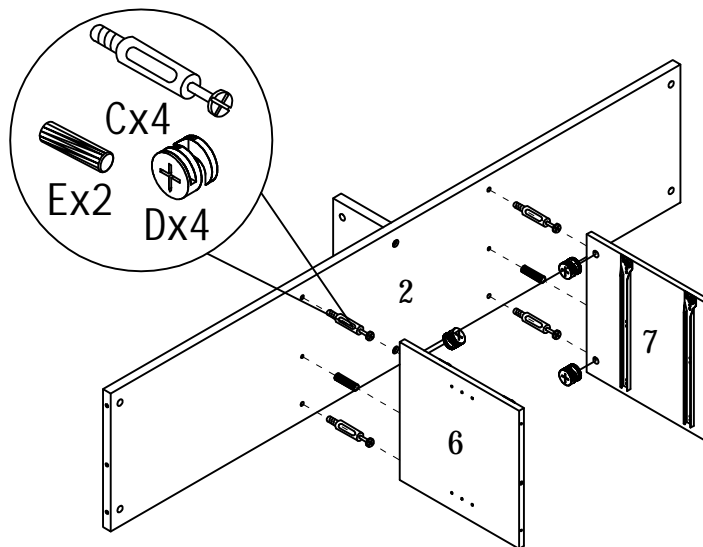

ITEM NO/NO MAL72TVS: 192509

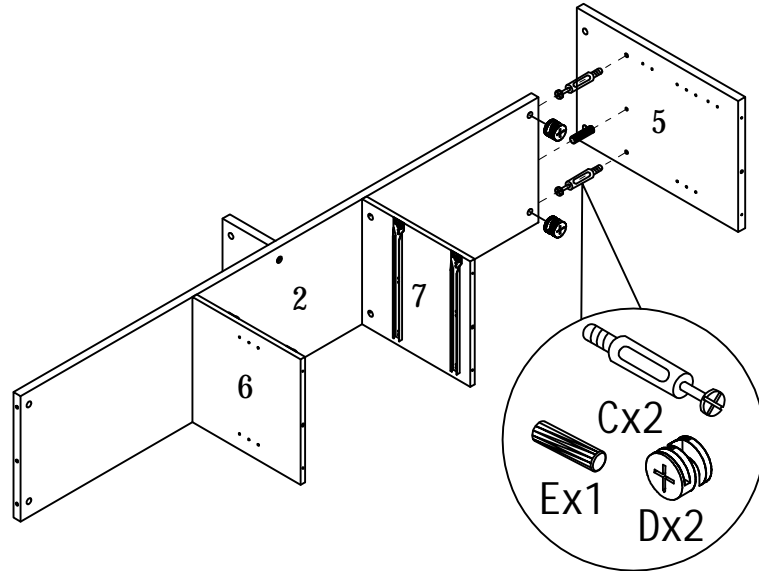

STEP 3 / ETAPE 3

STEP 4 / ETAPE 4

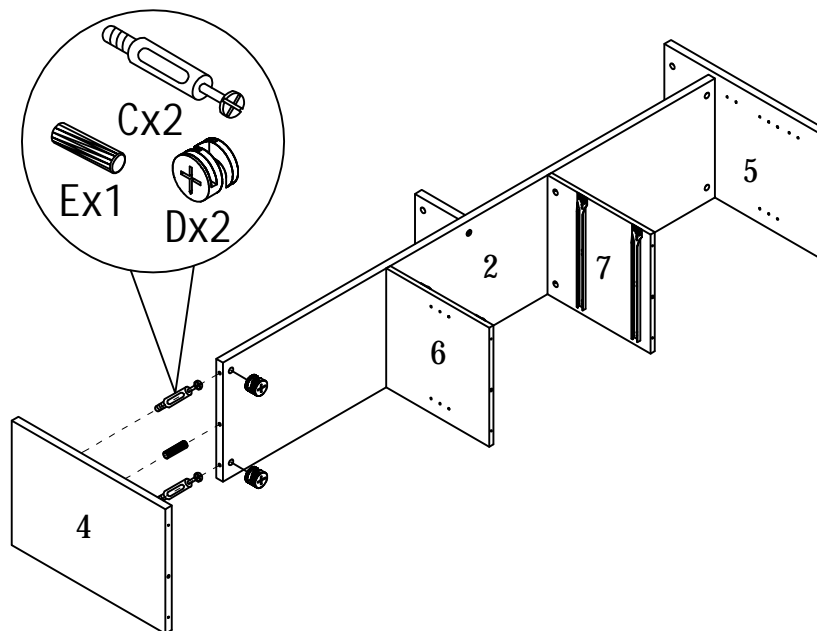

ITEM NO/NO MAL72TVS: 192509

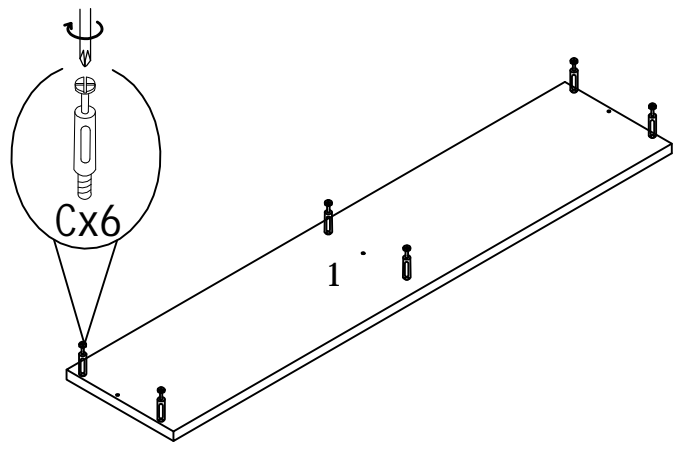

STEP 5 / ETAPE 5

STEP 6 / ETAPE 6

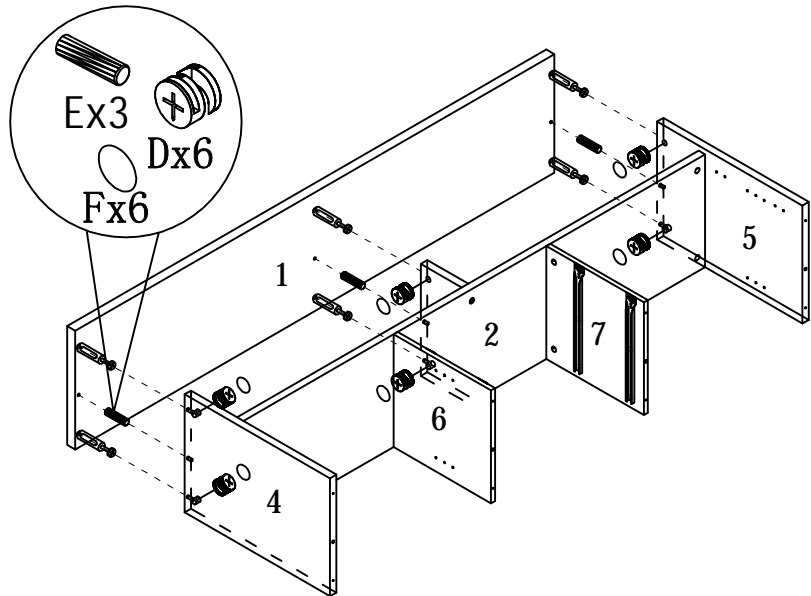

ITEM NO/NO MAL72TVS: 192509

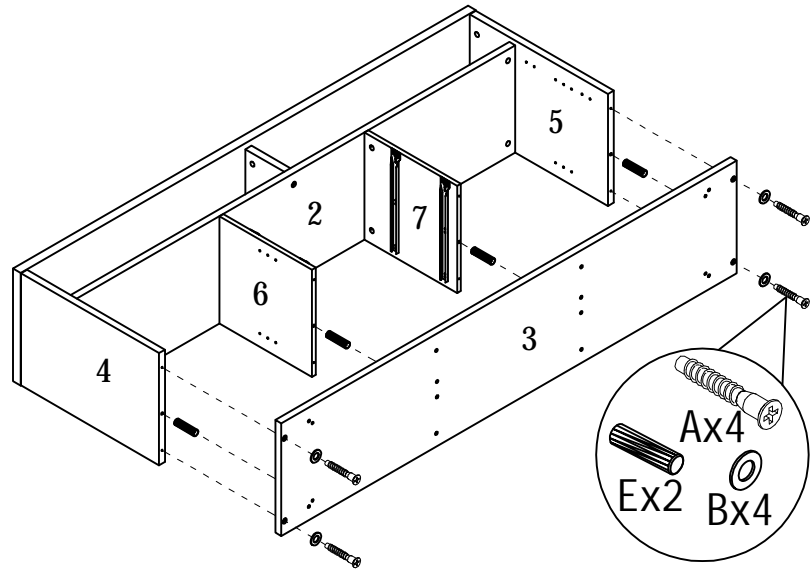

STEP 7 / ETAPE 7

STEP 8 / ETAPE 8

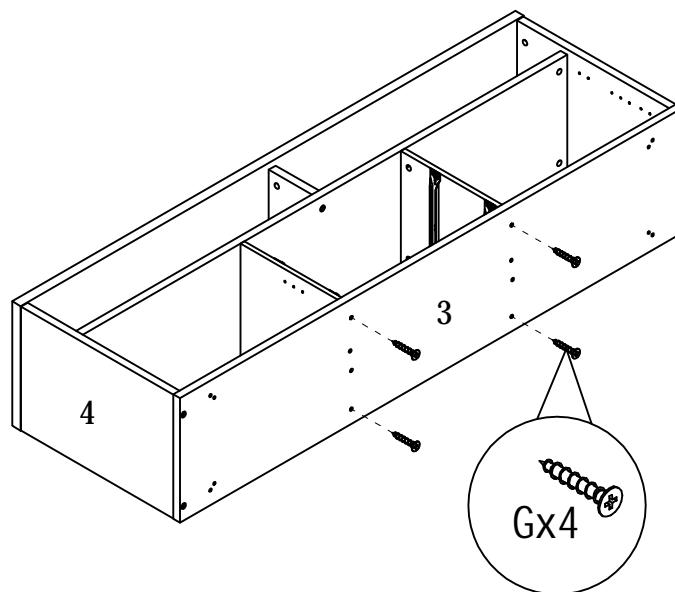

ITEM NO/NO MAL72TVS: 192509

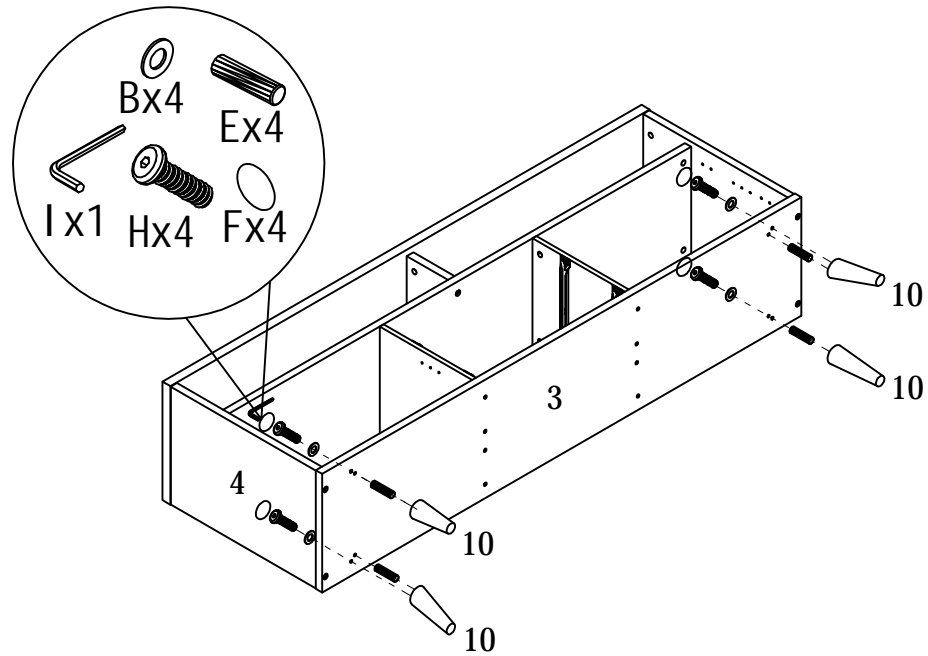

STEP 9 / ETAPE 9

STEP 10 / ETAPE 10

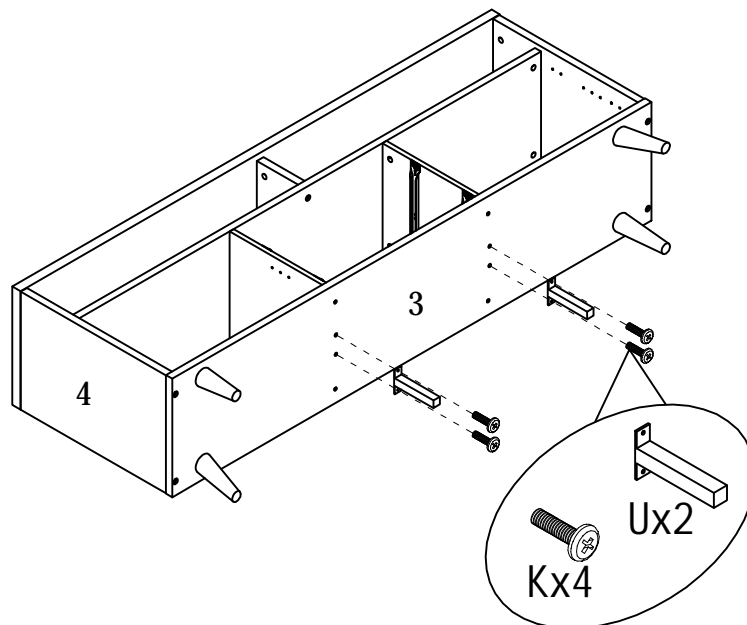

ITEM NO/NO MAL72TVS: 192509

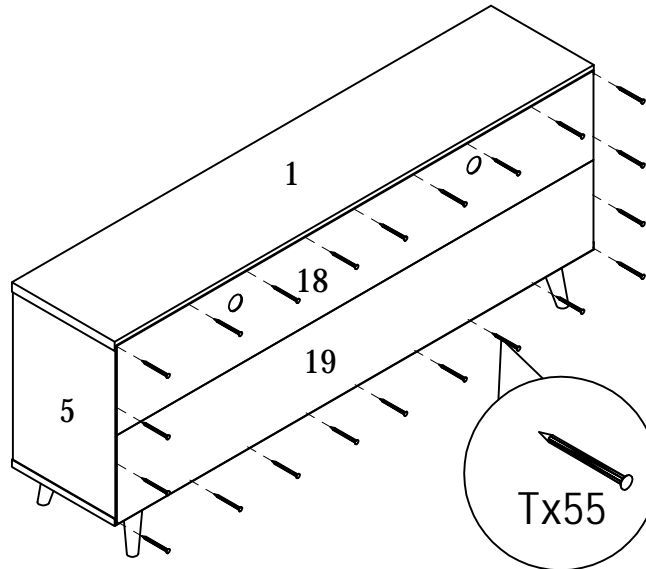

STEP 11 / ETAPE 11

STEP 12 / ETAPE 12

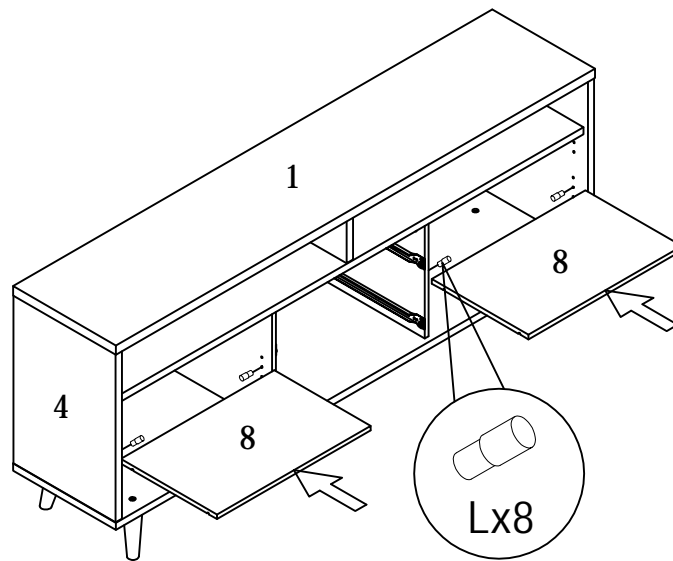

ITEM NO/NO MAL72TVS:192509

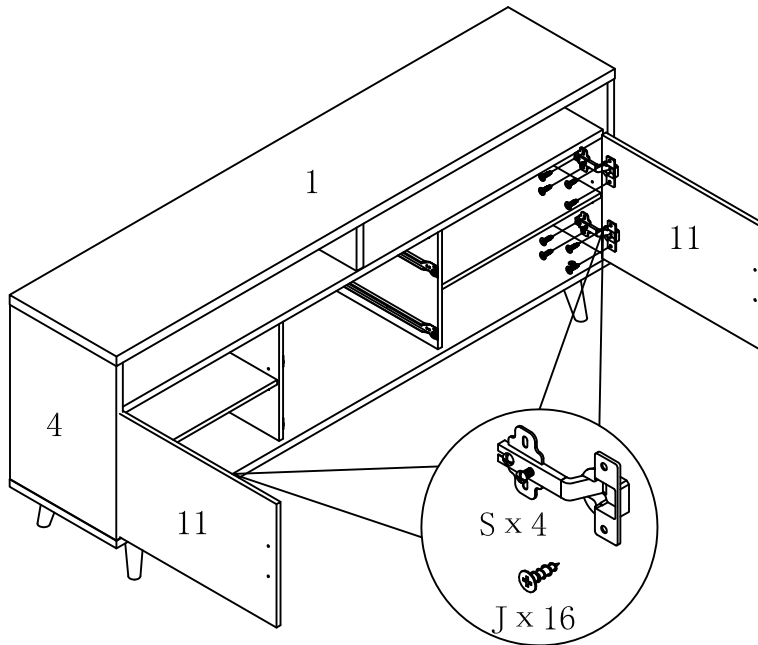

STEP 13 / ETAPE 13

To adjust the door in or out, loosen this screw and push the door further in or push further out then retighten screws.

1 - Pour ajuster la position de la porte vers l'intérieur ou de l'extérieur, desserrer les vis puis resserrer à fond les vis.

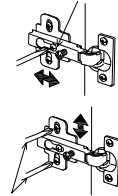

To adjust the door vertically, loosen the top and bottom screws, push the door up or down as necessary, then retighten screws.

2- Pour ajuster la porte verticalement, desserrer les vis de la partie supérieure et celles de la partie inférieure. Pousser la porte vers le haut et vers le bas puis serrer à fond les vis.

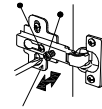

To adjust the door left/right, turn this screw clockwise to move this corner of the door toward the frame, or counterclockwise to move door away from the frame.

Pour ajuster la porte vers la gauche ou vers la droite, tourner les vis dans le sens des aiguilles d'une montre pour positionner le cadre de la porte vers l'avant ou dans le sens contraire des aiguilles d'une montre pour la positionner hors du cadre.

STEP 14 / ETAPE 14

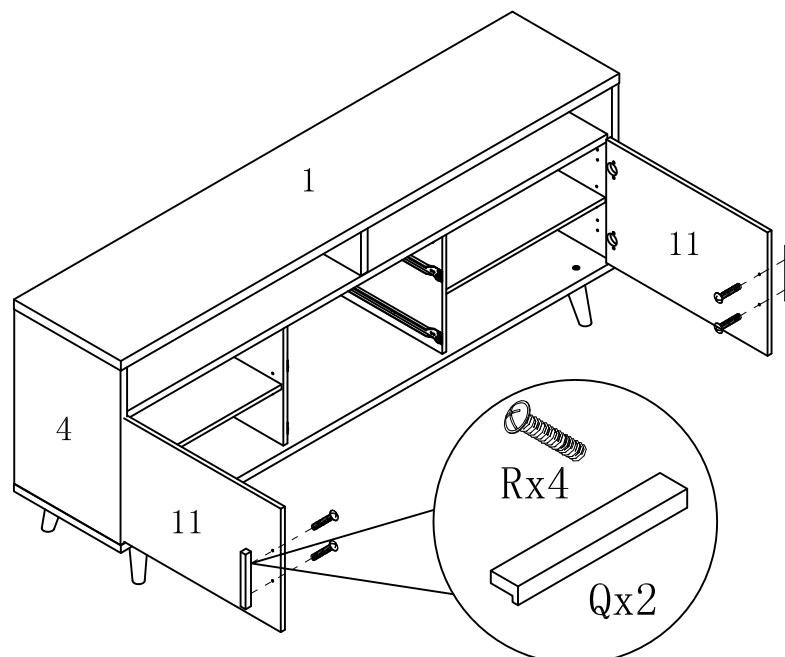

ITEM NO/NO MAL72TVS: 192509

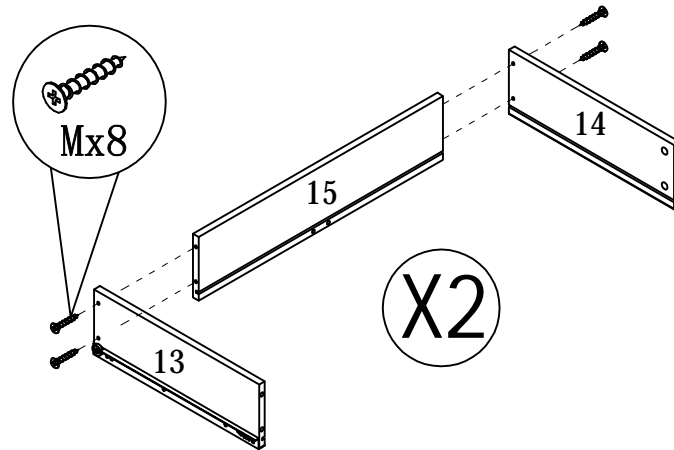

STEP 15 / ETAPE 15

STEP 16 / ETAPE 16

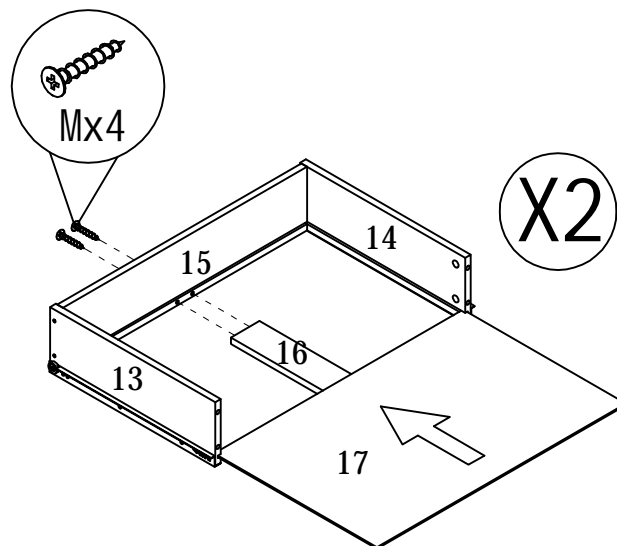

ITEM NO/NO MAL72TVS: 192509

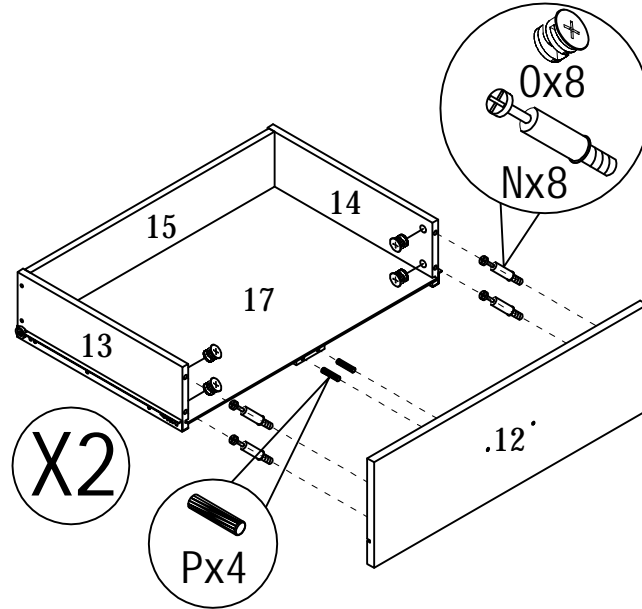

STEP 17 / ETAPE 17

STEP 18 / ETAPE 18

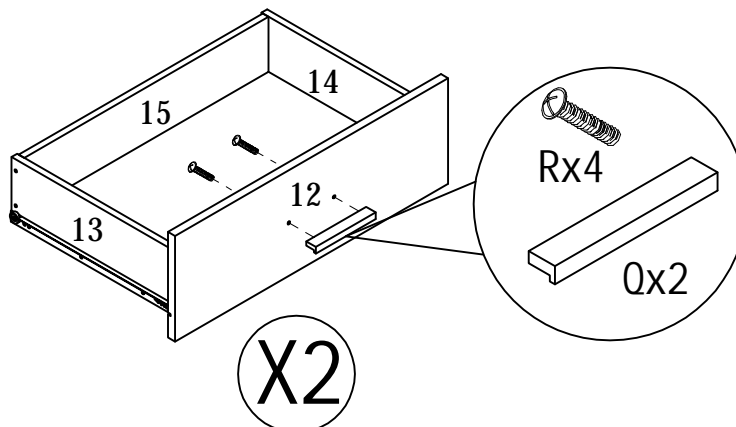

ITEM NO/NO MAL72TVS: 192509

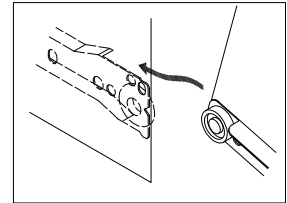
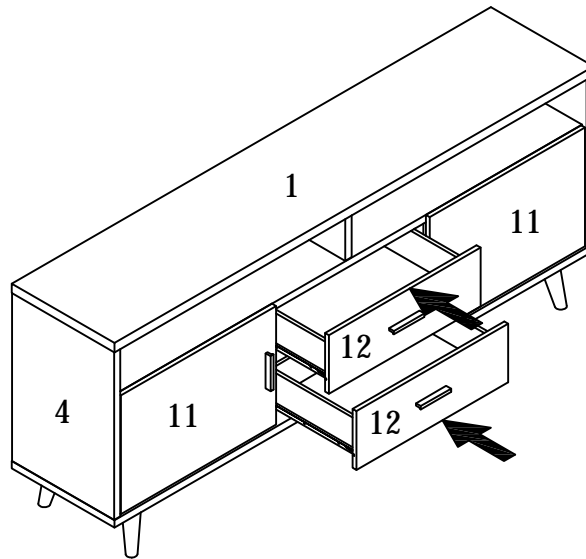

STEP 19 / ETAPE 19

STEP 20 / ETAPE 20

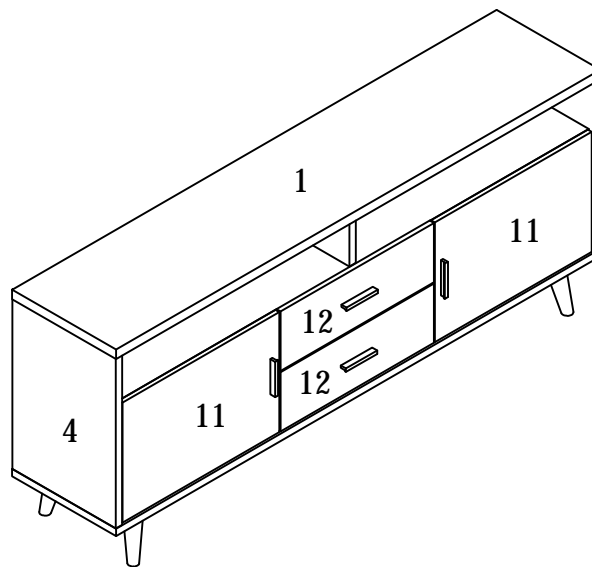

ASSEMBLY INSTRUCTIONS /
INSTRUCTIONS D'ASSEMBLAGE

ITEM NO/NO MAL72HUT: 192510

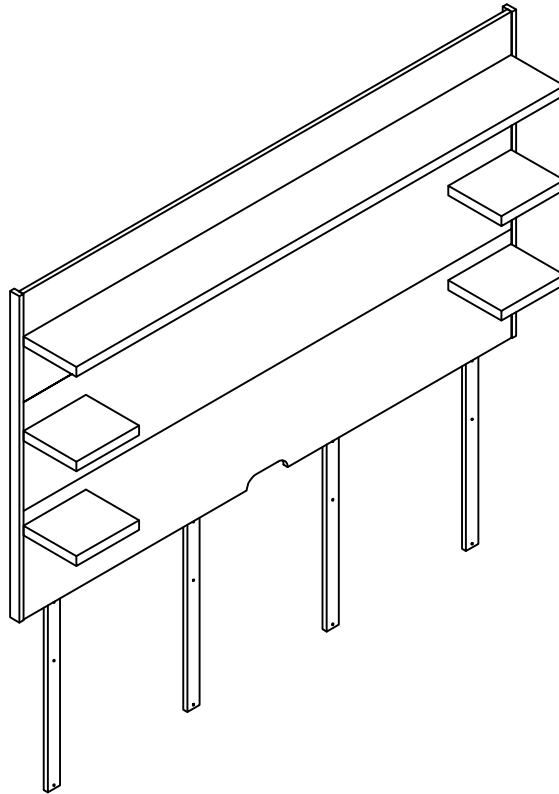

PARTS IDENTIFICATIONS / IDENTIFICATION DES PIECES



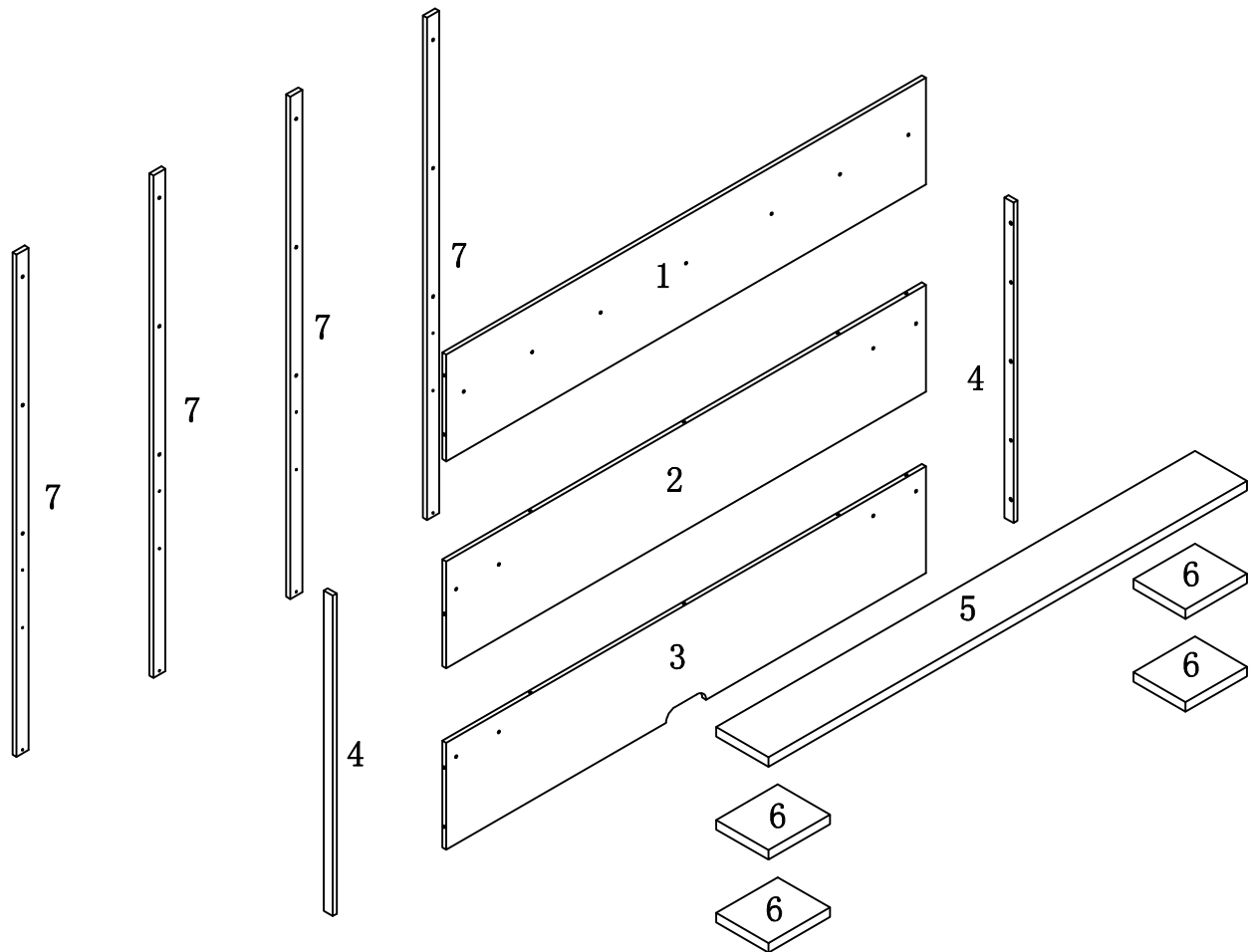







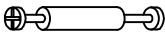

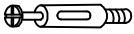
ITEM NO/NO MAL72HUT: 192510

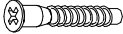

- | | |
|-----|----------|
| (1) | 1pc/pce |
| (2) | 1pc/pce |
| (3) | 1pc/pce |
| (4) | 2pcs/pce |
| (5) | 1pc/pce |
| (6) | 4pcs/pce |
| (7) | 4pcs/pce |

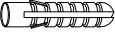
HARDWARE IDENTIFICATIONS/ IDENTIFICATION DU KIT D'ASSEMBLAGE

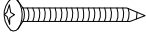
ITEM NO/NO MAL72HUT: 192510

| | | | |
|---|---|--|-----------|
| A |  | L60 | 8pcs/pcs |
| B |  | Φ 15 | 22pcs/pcs |
| C |  | Φ 8x25 | 13pcs/pcs |
| D |  | L29 | 6pcs/pcs |
| E |  | M6x25 | 12pcs/pcs |
| F |  | M7x58 | 12pcs/pcs |
| G |  | Φ 8x Φ 16x2 | 12pcs/pcs |
| H |  | Φ 4x40 | 12pcs/pcs |
| I |  | 197x5x1 | 2pcs/pcs |
| J |  | Φ 8x40 | 2pcs/pcs |
| K |  | 12x12x1 | 4pcs/pcs |
| L |  | Φ 5x40 | 2pcs/pcs |
| M |  | Φ 4x25 | 2pcs/pcs |
| N |  | Glue: For securing please apply to wood dowel first before inserting into panel. Colle: Appliquez de la colle sur les goujons en bois avant de les insérer dans le panneau. | 1pc/pcs |

ITEM NO/NO MAL72HUT: 192510

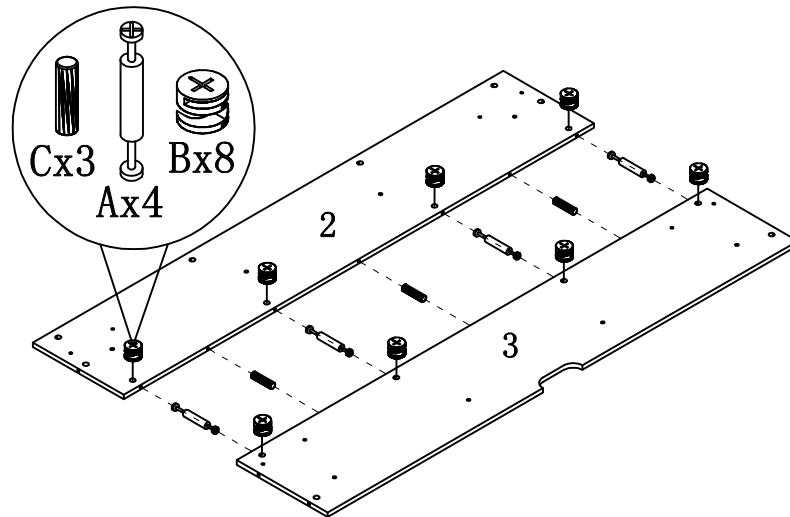

STEP 1 / ETAPE 1

STEP 2 / ETAPE 2

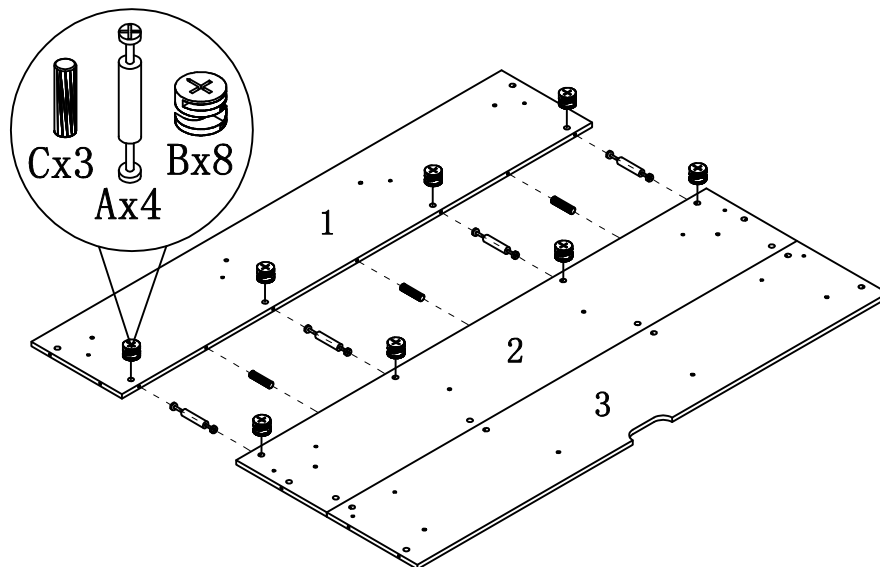

ITEM NO/NO MAL72HUT: 192510

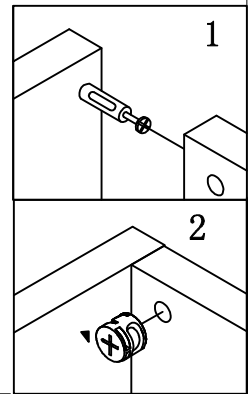
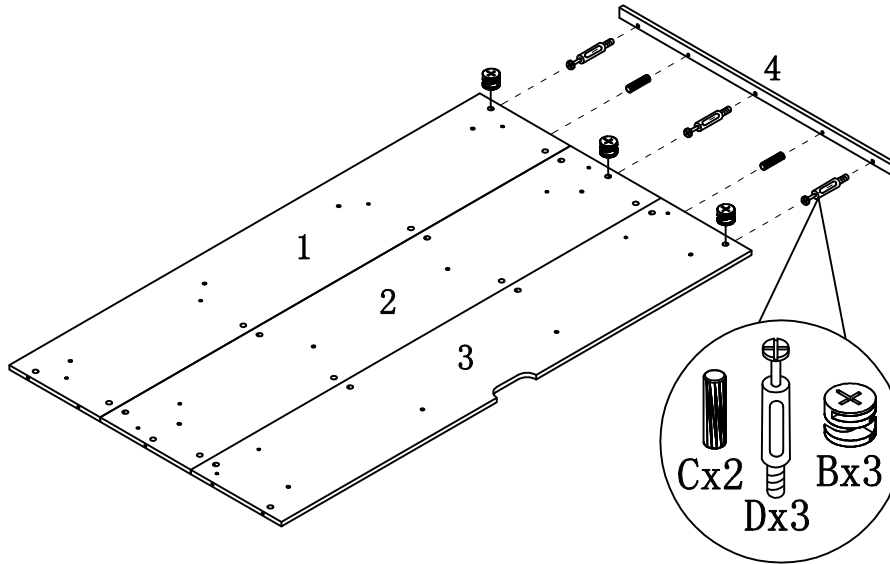

STEP 3 / ETAPE 3

STEP 4 / ETAPE 4

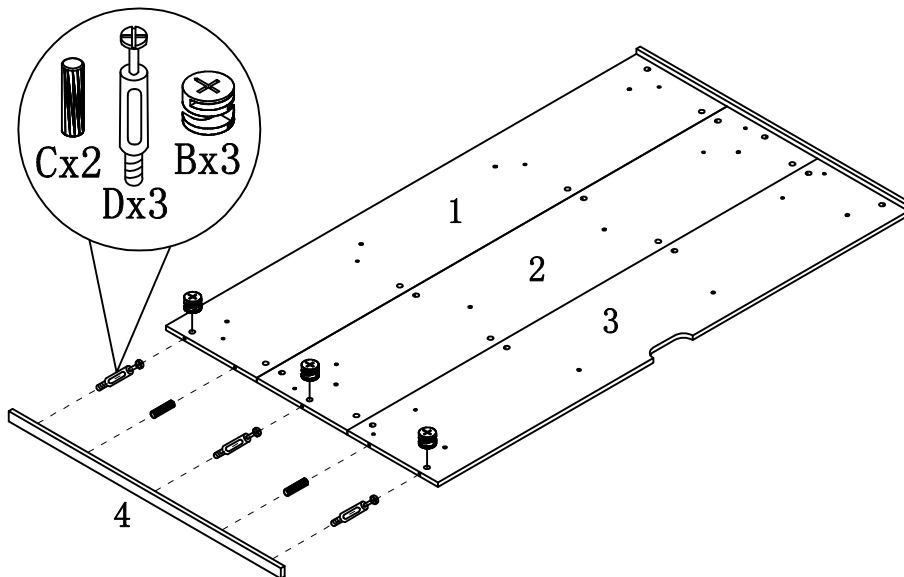

ITEM NO/NO MAL72HUT:192510

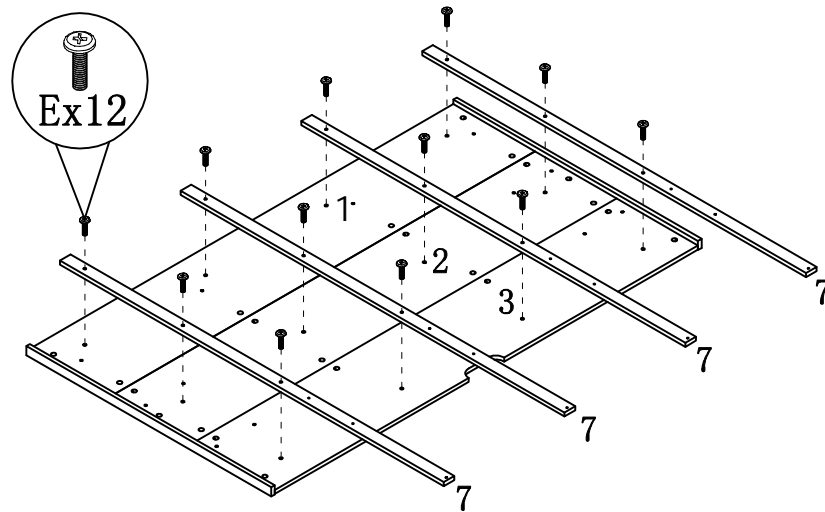

STEP 5 / ETAPE 5

STEP 6 / ETAPE 6

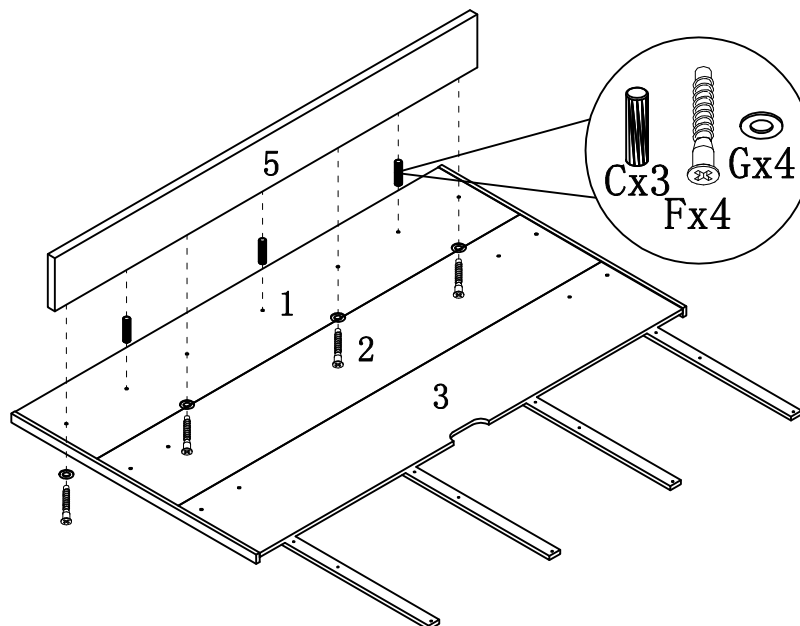

ITEM NO/NO MAL72HUT:192510

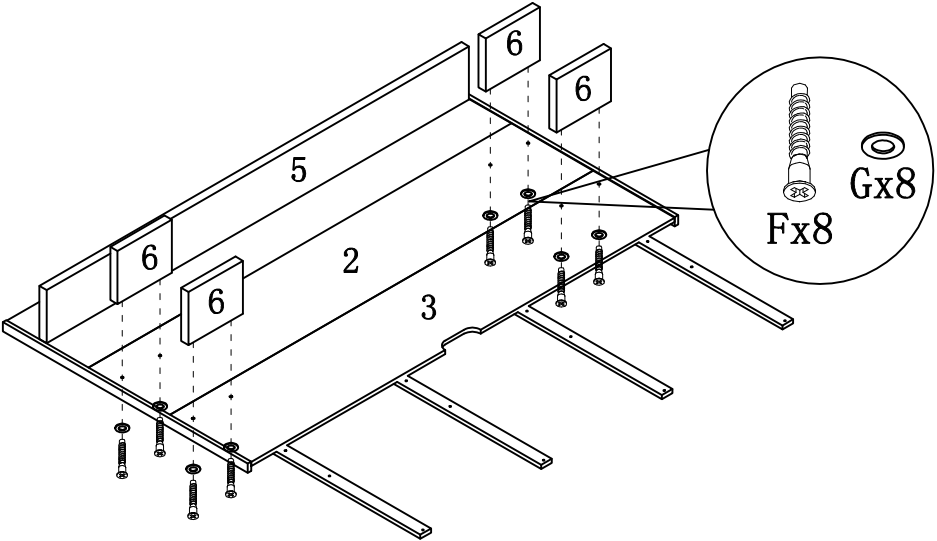

STEP 7 / ETAPE 7



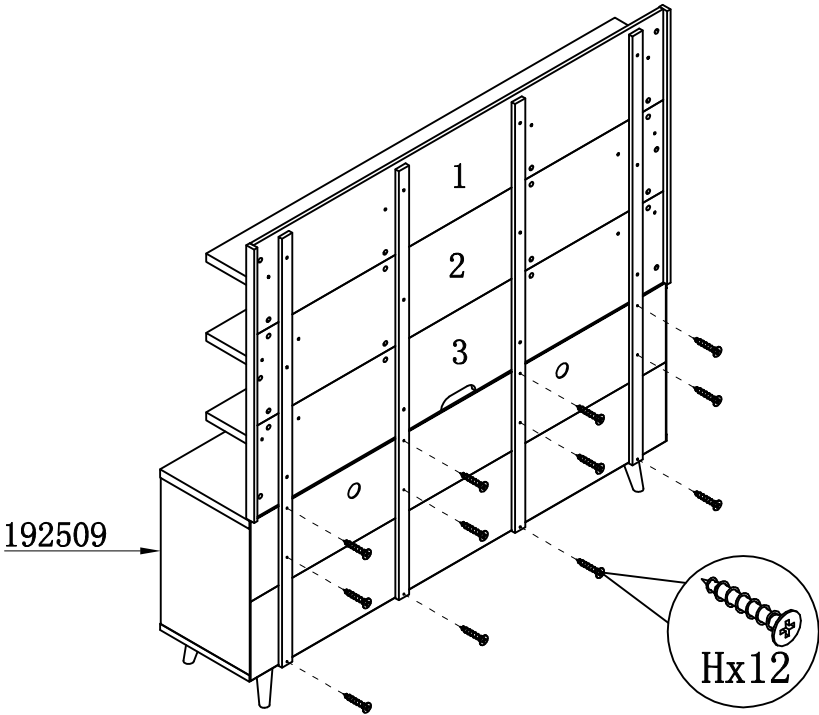

STEP 8 / ETAPE 8

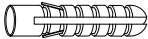
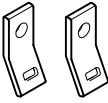

ANTI-TIPPING STRAP INSTRUCTION

Instructions pour sangle anti-basculement

Quincallerie (Incluse):

-  DRYWALL ANCHOR $\phi 8 \times 40$ X 1PCS
-  Fixation en métal $12 \times 12 \times 1$ X 2PCS
-  Vis $\phi 5 \times 40$ X 1PCS
-  Sangle $197 \times 5 \times 1$ X 1PCS
-  Vis $\phi 4 \times 25$ X 1PCS

Outils requis (Non inclus):

-  DRILL & DRILL BIT
Perceuse et trépan
-  LIGHT HAMMER
Marteau léger

Note: Hardware included only compatible with standard drywalls. :Notez que la quincallerie incluse est compatible avec les ancrages de mur standard

Step 1 Étape 1

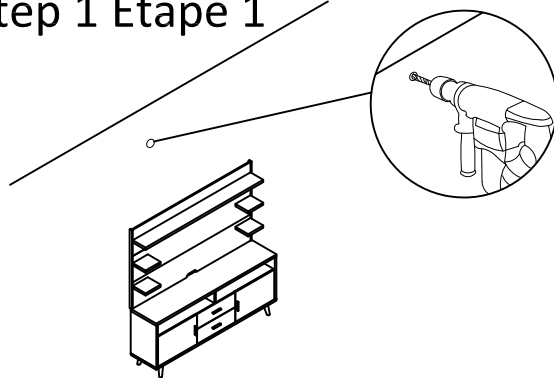

1. Find spot on wall 1" below the top of item.
Placer sur le mur à 1 pouce au-dessus de l'article.
2. Using a drill bit slightly smaller than the gauge of anchor, drill a hole, then place the anchor into wall.
À l'aide d'un trépan légèrement plus petit qu'un ancrage en acier de jauge, percer un trou puis placer l'ancrage dans le mur.

Step 2 Étape 2

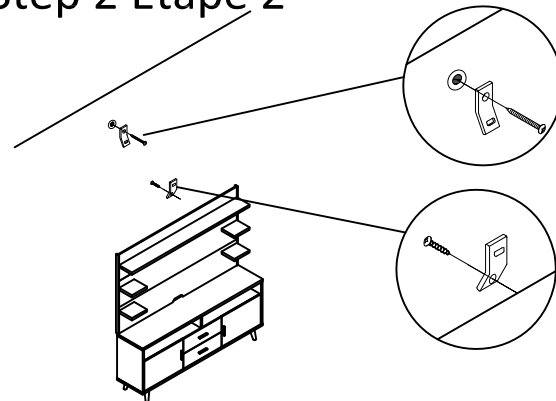

1. Screw the metal bracket into the anchor of wall.
Visser la première fixation en métal à l'intérieur de l'ancrage de mur.
2. Screw the second metal bracket into the back of item along the of soleid frame.
Visser la deuxième fixation à l'arrière de l'article.

Step 3 Étape 3

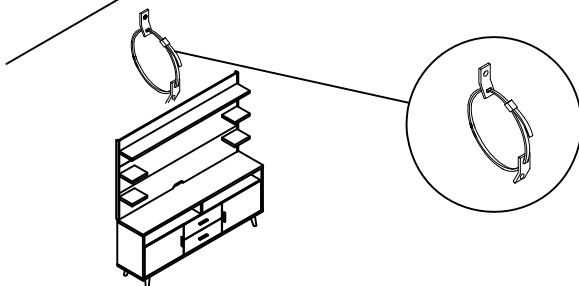

1. Insert strap thru the bracket attached to wall and the second attached to the product.
Insérer la sangle à l'intérieur de la fixation en métal. Elle s'attache facilement sur l'arrière du meuble, l'autre bout étant fixé au mur.
2. Pull tightly: Et puis tirer fermement.