

ASSEMBLY INSTRUCTION

ITEM# 19739SKF SKU#JACEGKSF
DESCRIPTION:Jace GRY STG FB/RL/SL - KG

INSTRUCTION D'ASSEMBLAGE

DESCRIPTION:Pied de L,lattes,longerons-gris Très grand

Parts/Pièces

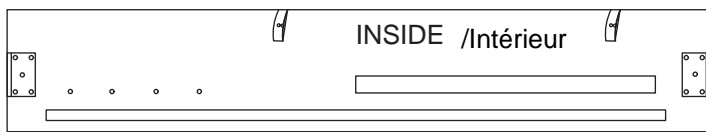

1 Right side rail/Longerons latéraux droits

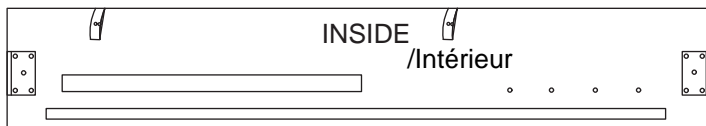

2 Left side rail /Longerons latéraux gauches

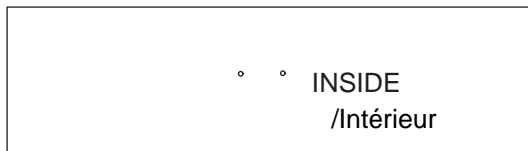

4 Footboard/Pied de lit

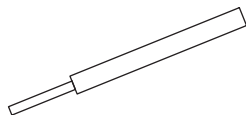

6 Piston/Piston x 2

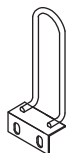

8 Mattress support bracket x 2 /Bride de fixation pour matelas

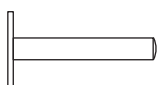

10 Long support leg x 4 /Pieds de support -Longs



12 Ottoman end frame (Footboard) x 1 (Note: Chamfered corners) /Bout d'armature pour ottomane(Pied de L) Note:Bords chanfreinés

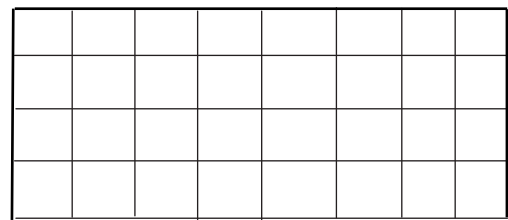

FRONT /Avant

3 Headboard/Tête de lit

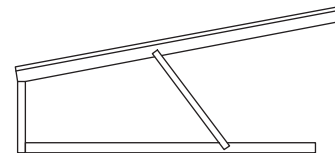

5 Hinges/Charnières x 2



7 Base panel x 7 /Base de panneau

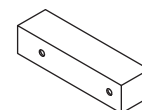

9 Ottoman frame support x 1 /Armature de support pour ottomane



11 Ottoman end frame (Headboard) x 1 /Bout d'armature pour ottomane

Parts

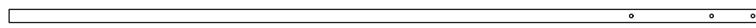

13 Ottoman frame (Sides) x 2
/Armature d'ottomane(Coins)



14 Ottoman frame centre rail x 2
/Traverse centrale- armature pour ottomane



15 Double slat caps x 38
/Capuchons de lattes de lit double



16 Wooden support rail x 5
/Longeron de support en bois



17 Bentwood slats x 57
/Lattes en bois courbé



18 Single slat caps x 38
/Capuchons de lattes de lit simple



19 Short support leg x 10
/Pied de support -Court



20 The board for headboard x 1

Hardware/Quincaillerie

A

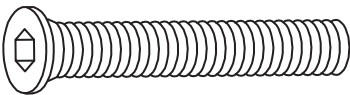

5/16*2"*2pcs

B

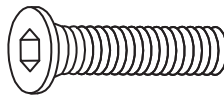

5/16*1"*30pcs

C

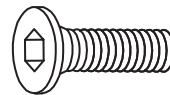

1/4*3/4"*20pcs

D

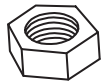

Nut x 4
/écrous

E

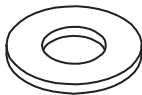

19mm Flat washer** 36pcs
/rondelle plate

F

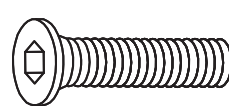

1/4*1"*6pcs

G



35mm M4 Wood screw x 4PCS

H



15mm M4 Wood screw x 8PCS

I



I-beam bars x4pcs

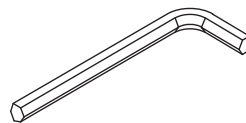

4mm Allen key
/clé Allen

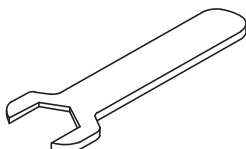

Spanner/clé

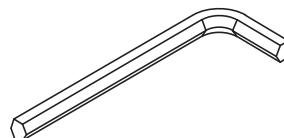

5mm Allen key
/clé Allen

1

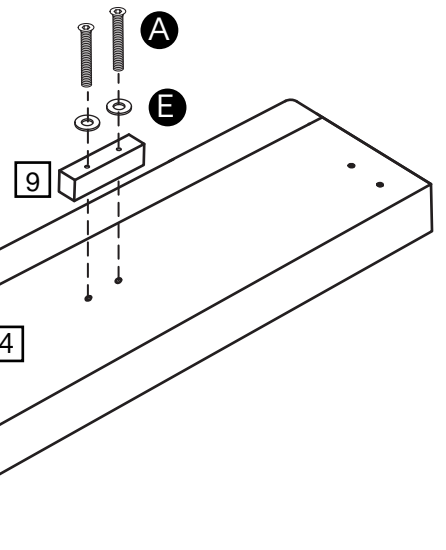
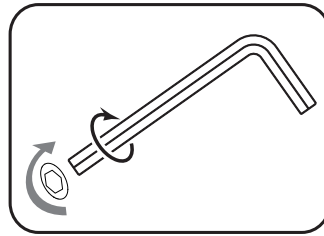
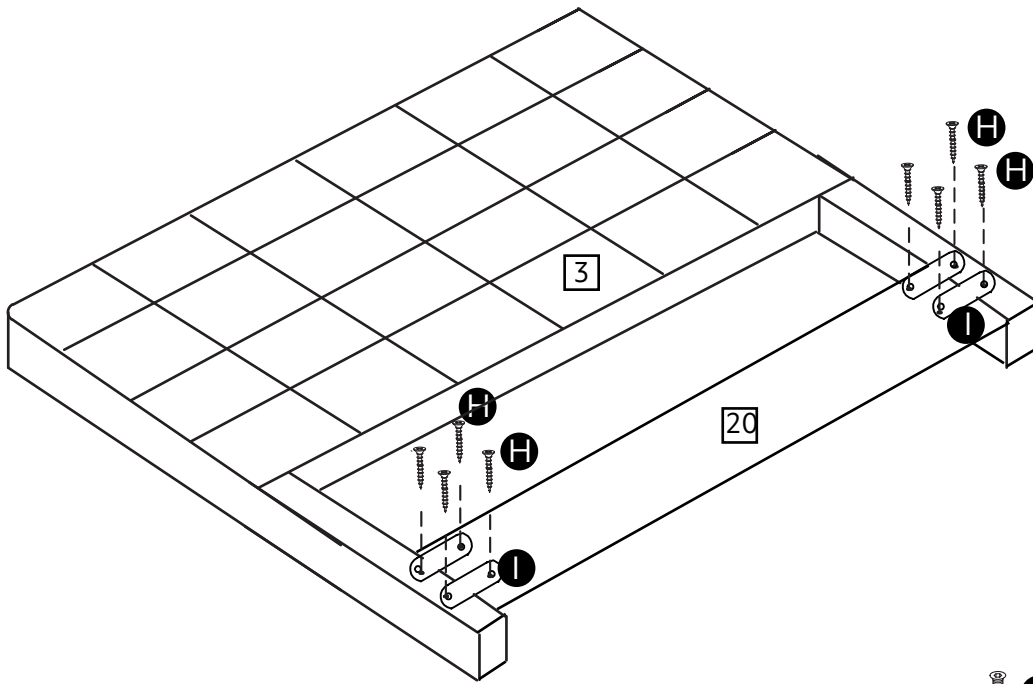

2

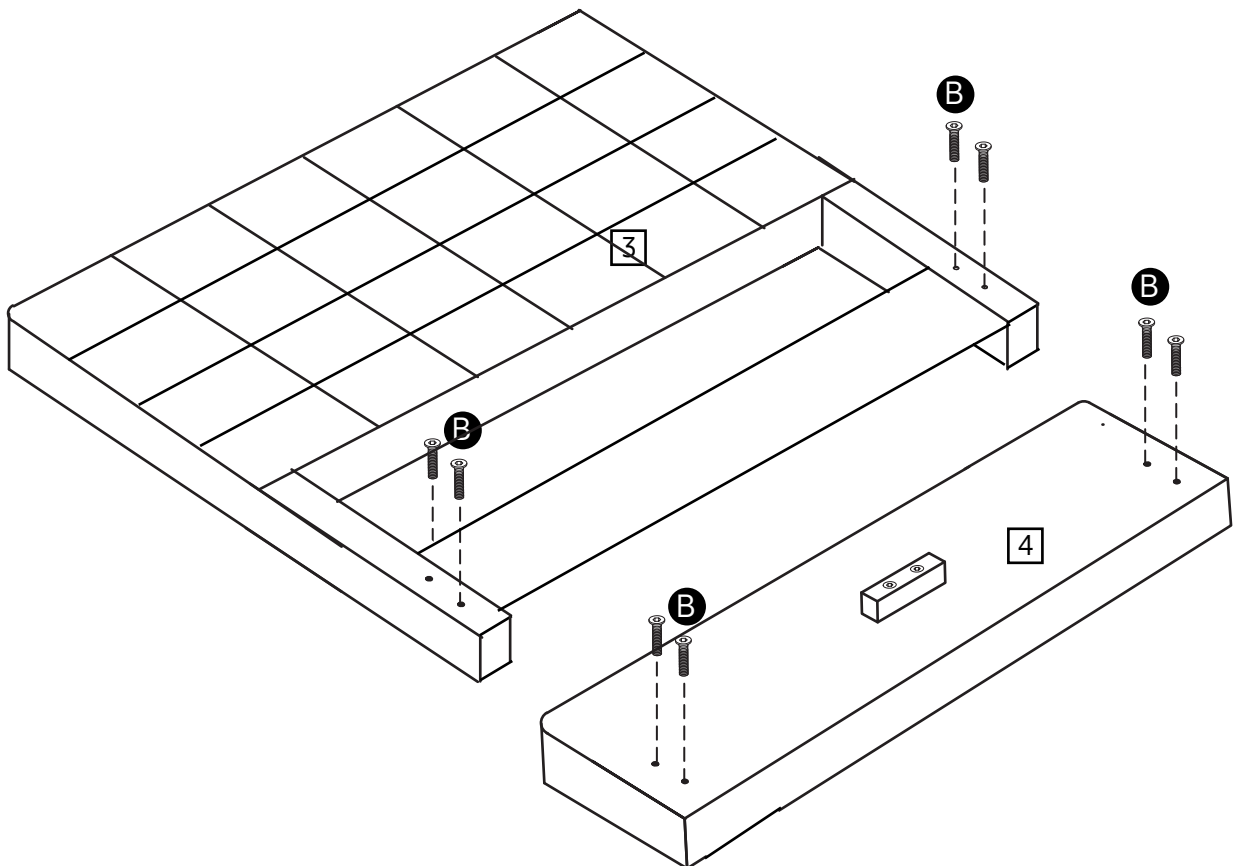

3

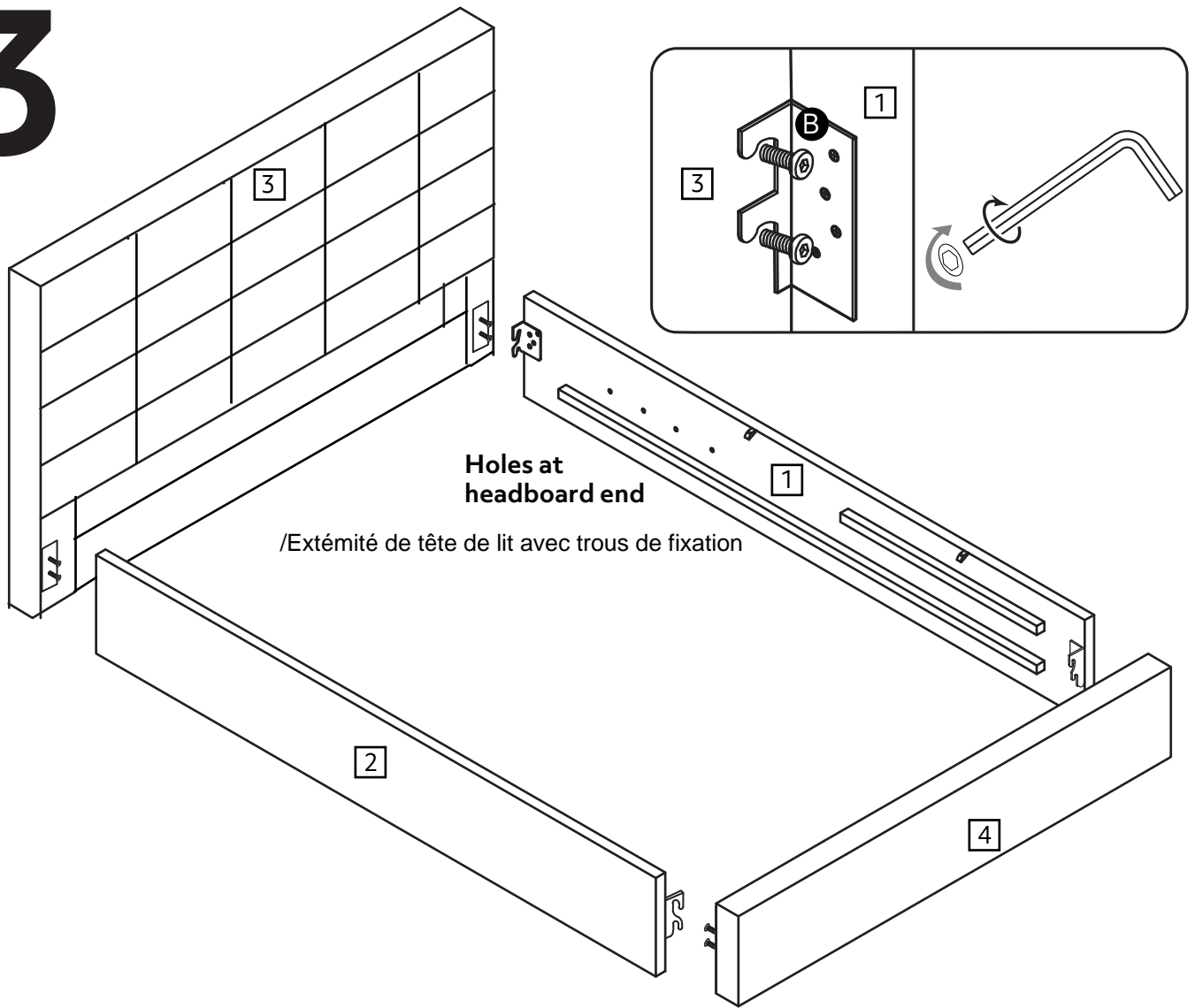

4

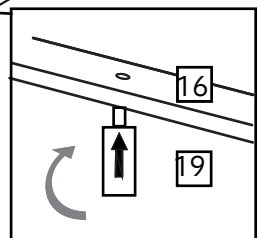
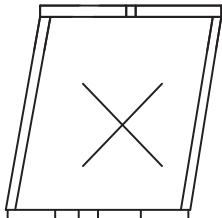
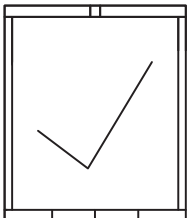
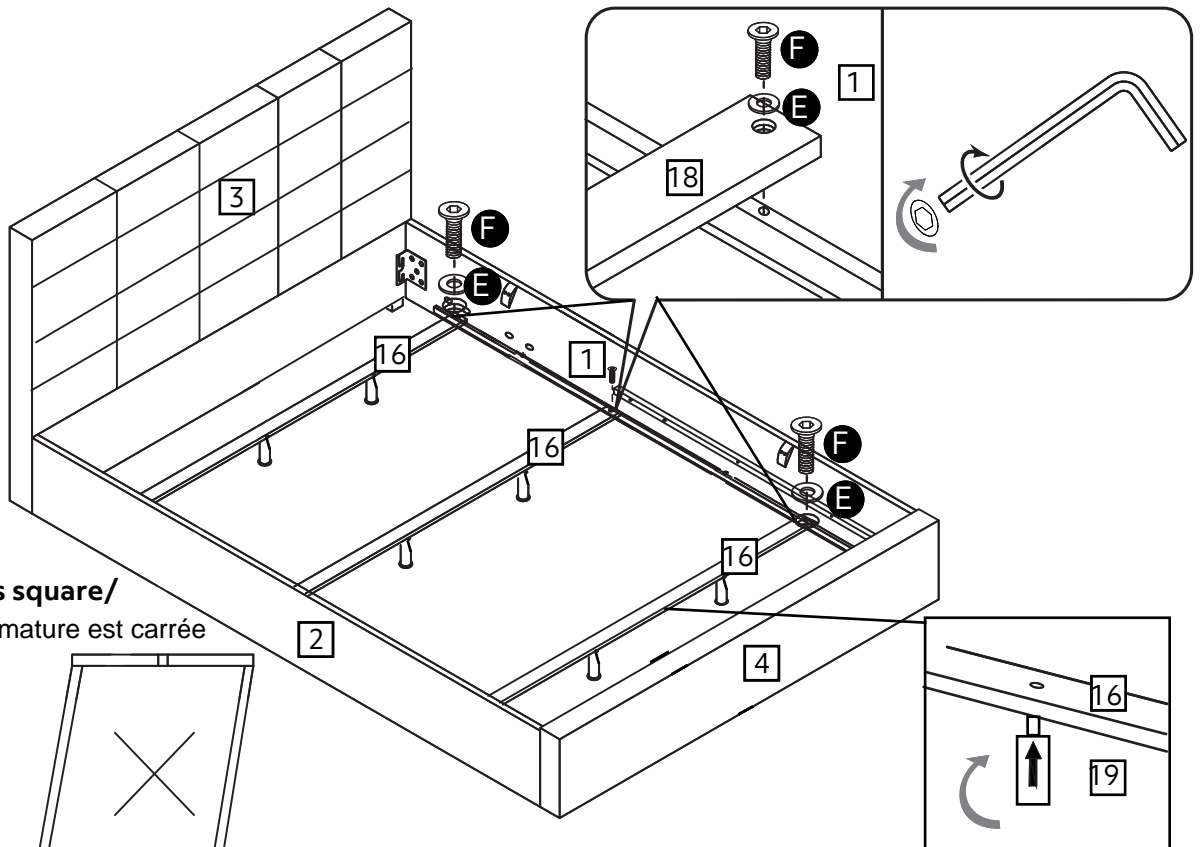

5

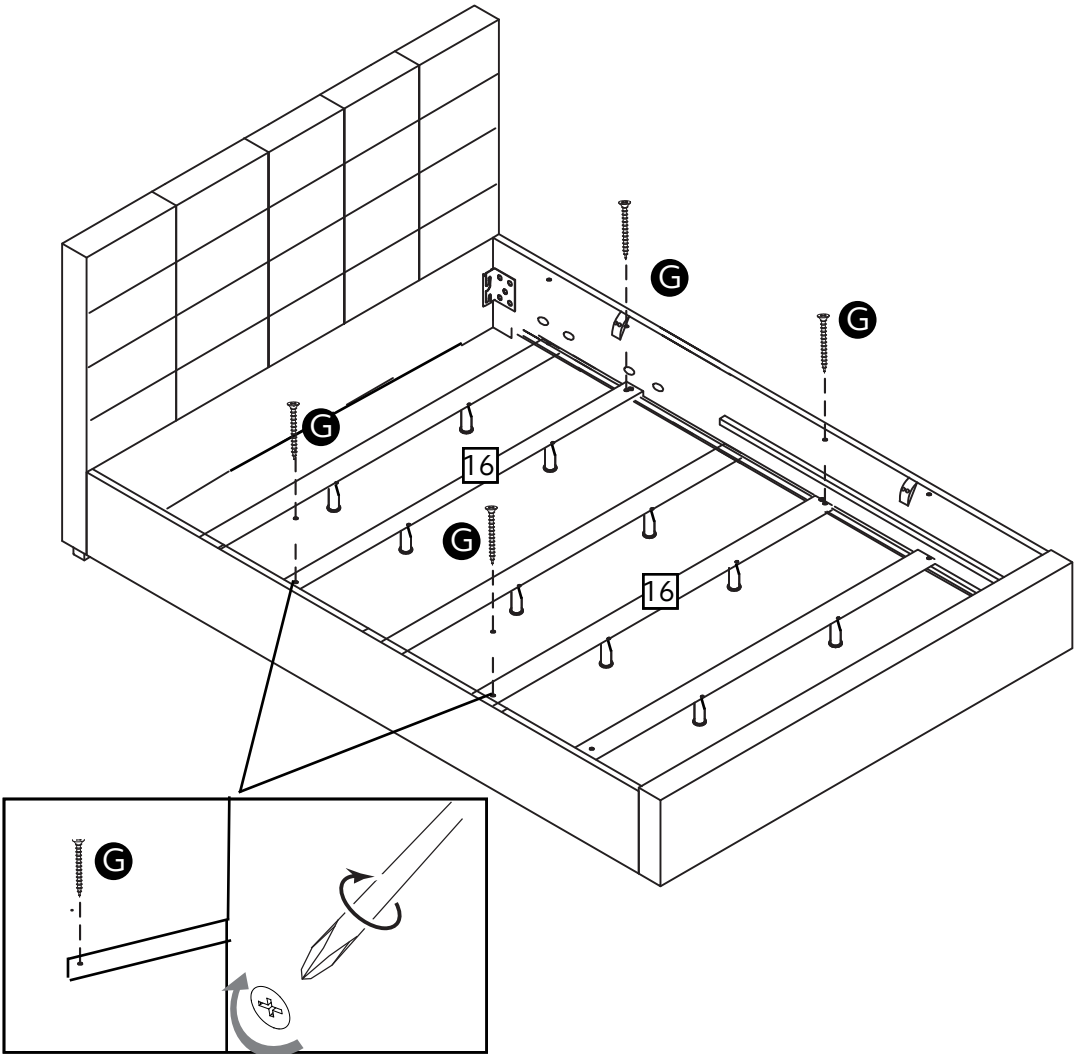

6

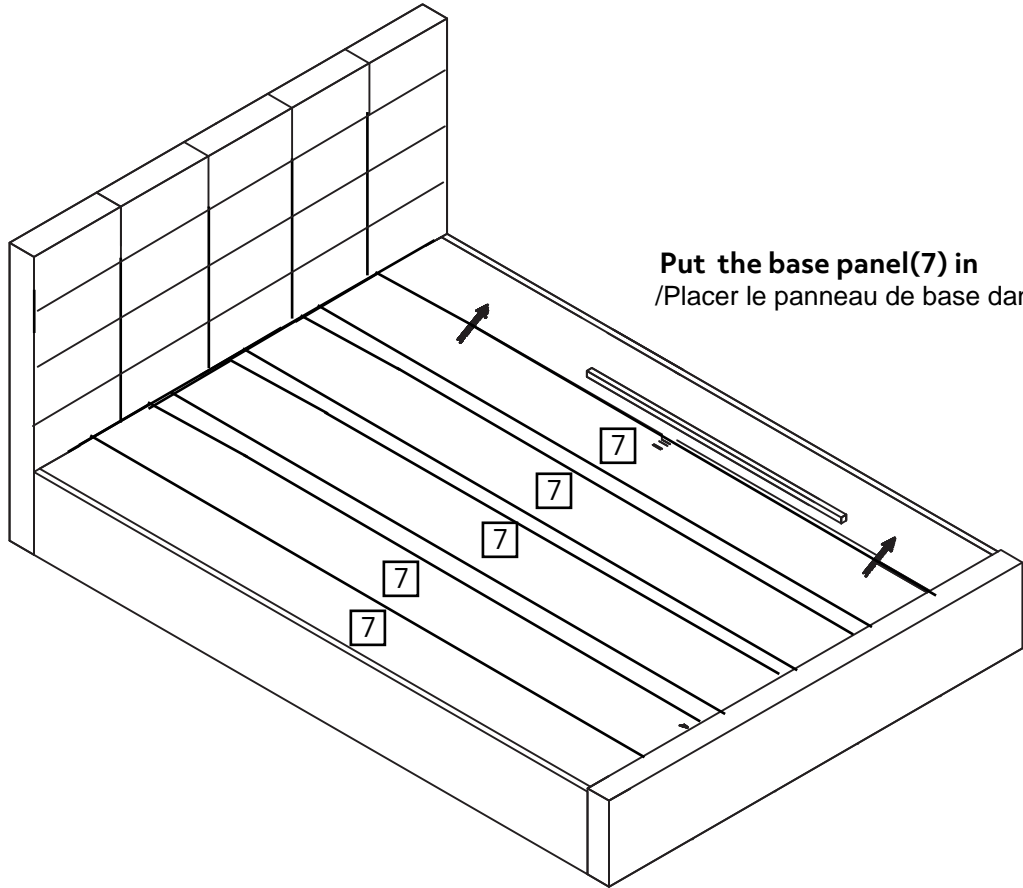

7

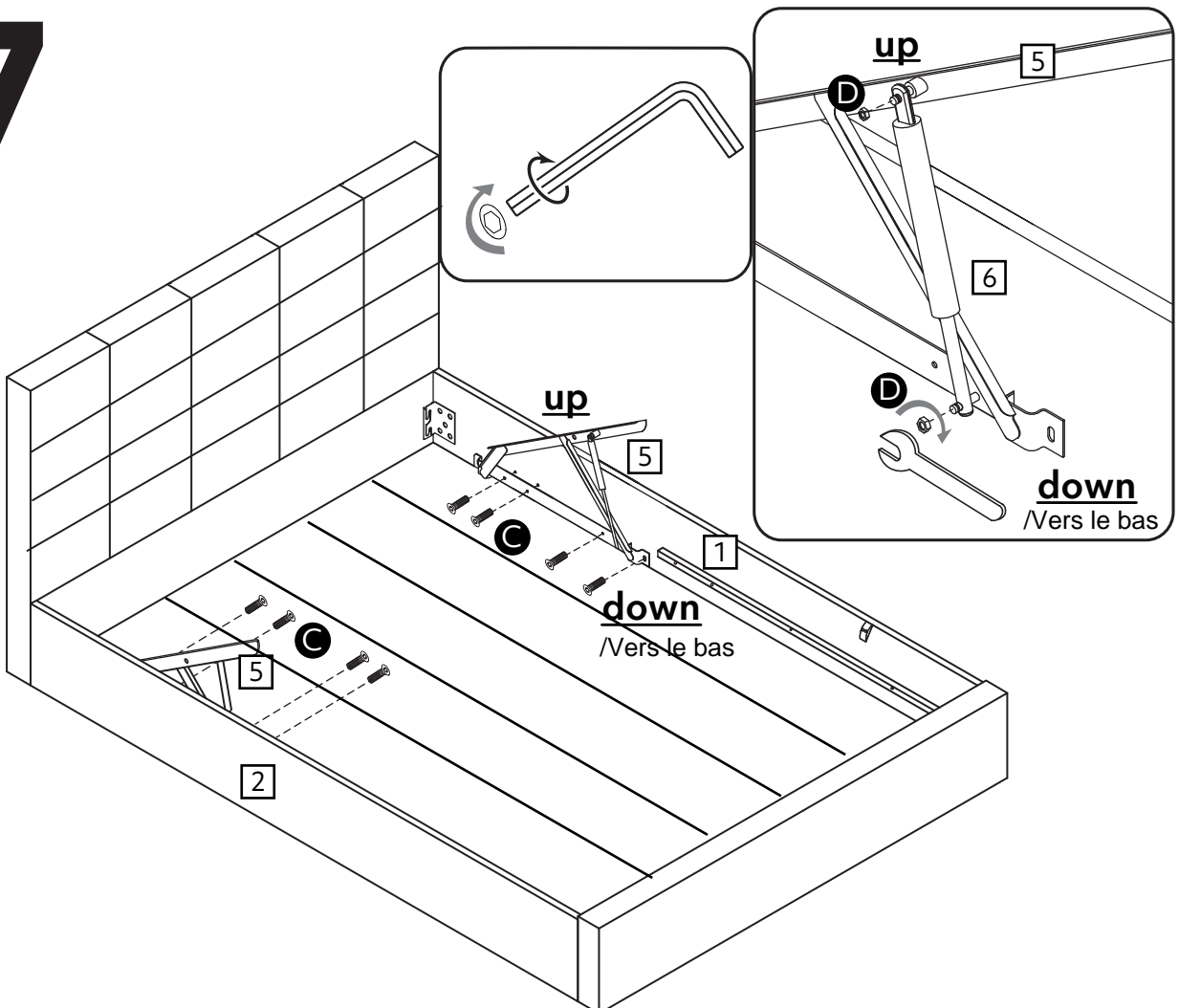

8

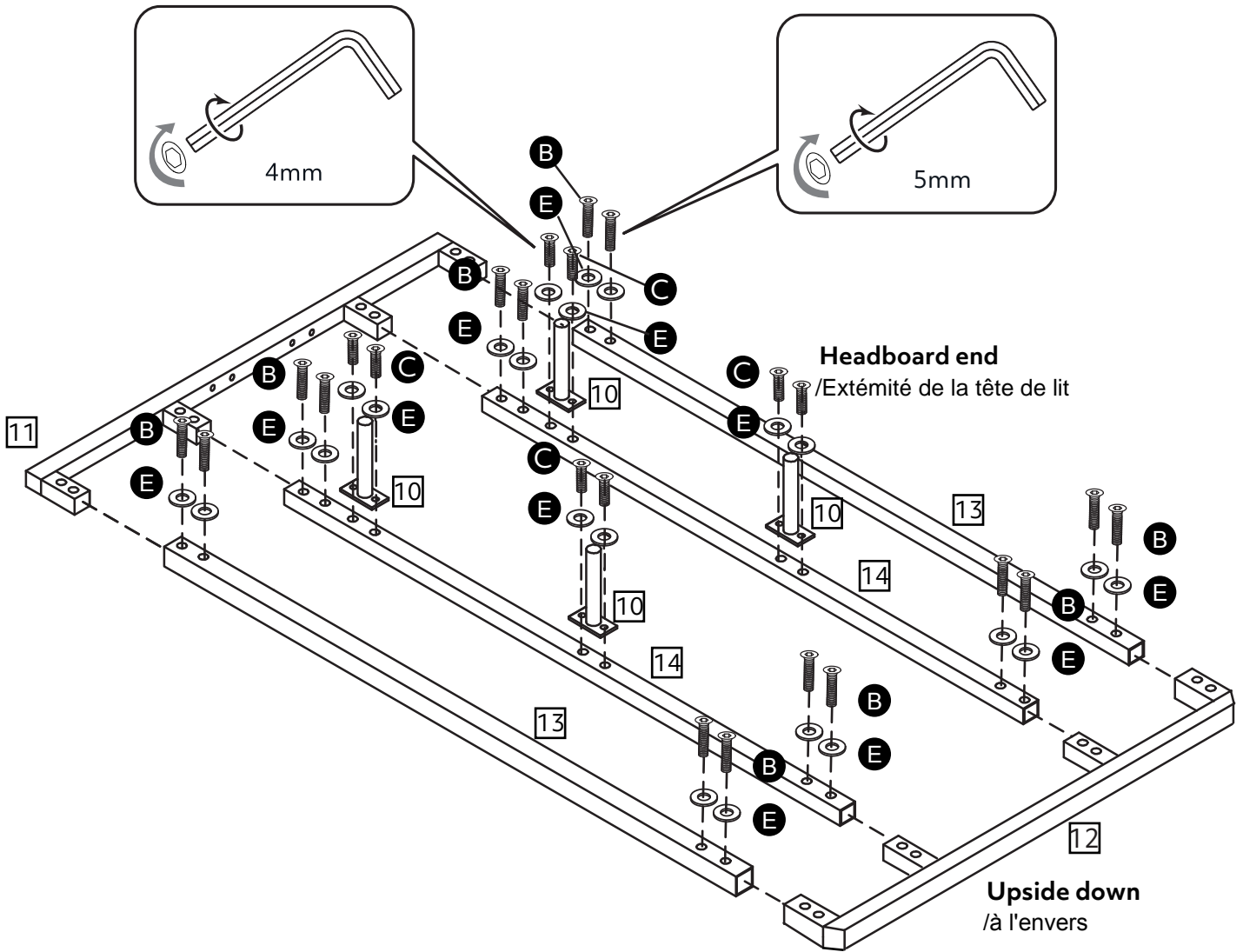

Do not fully tighten screws
/Ne pas visser complètement les vis

9

Headboard end
/Extémité de la tête de lit

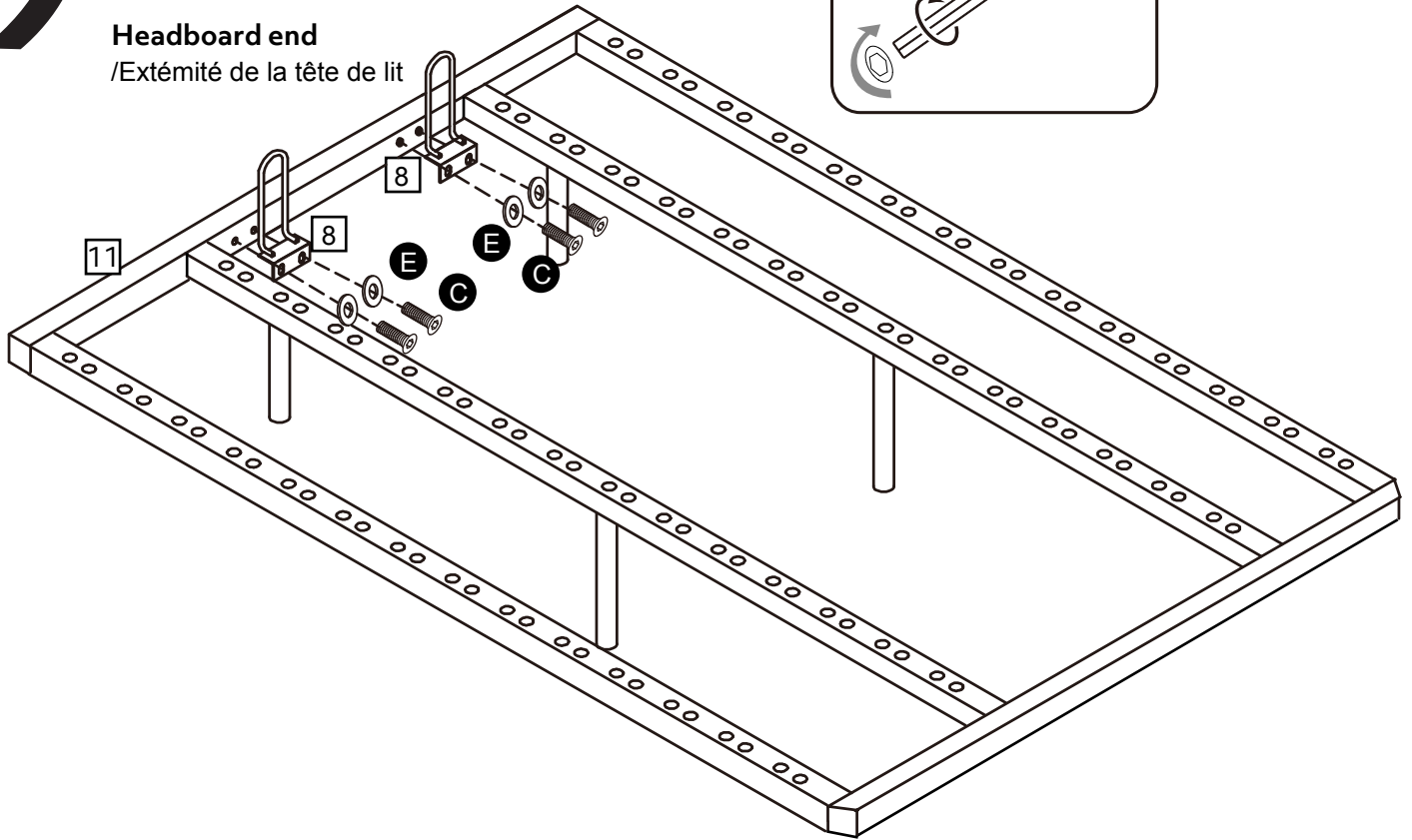

10

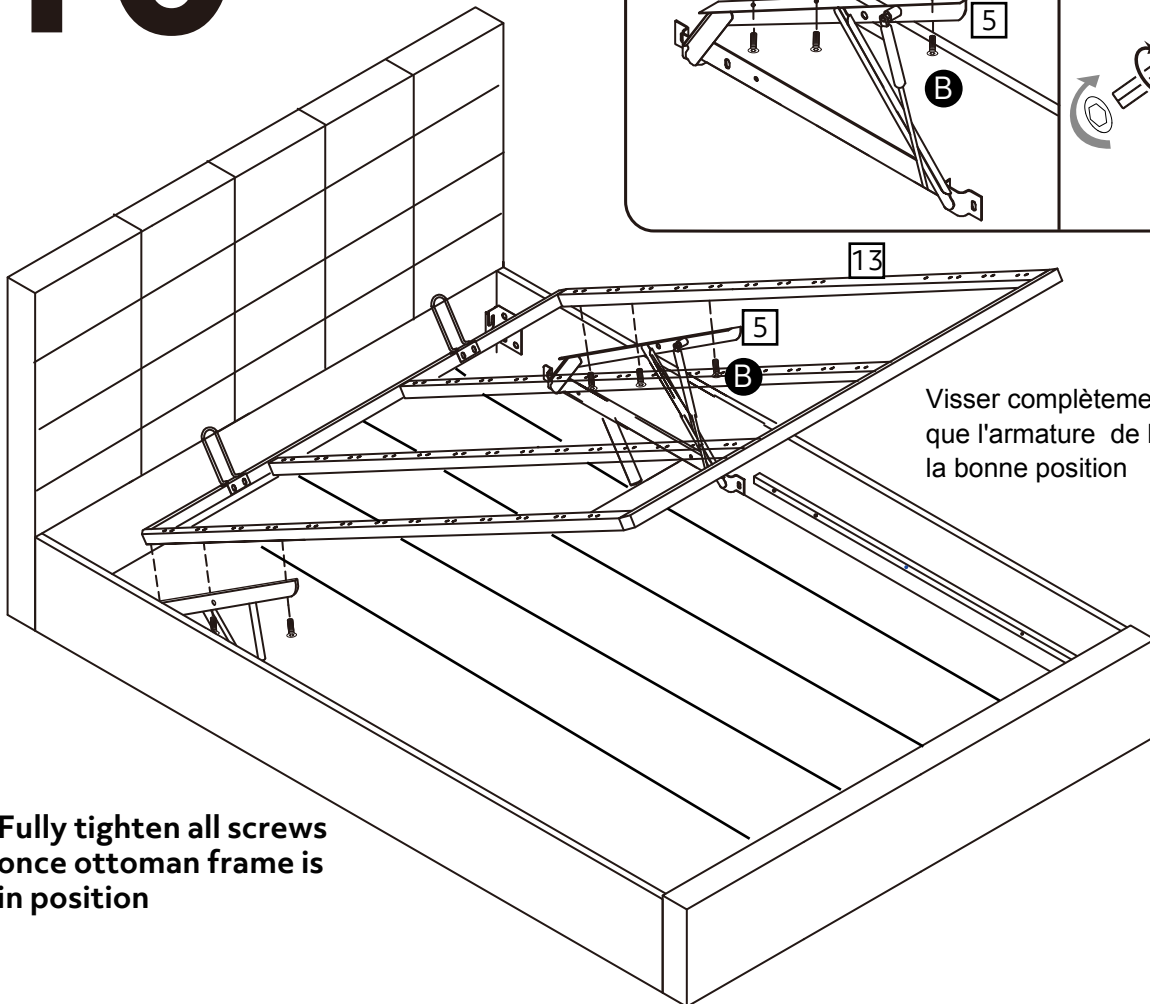

Fully tighten all screws
once ottoman frame is
in position

Visser complètement les vis jusqu'à ce
que l'armature de l'ottomane est dans
la bonne position

11

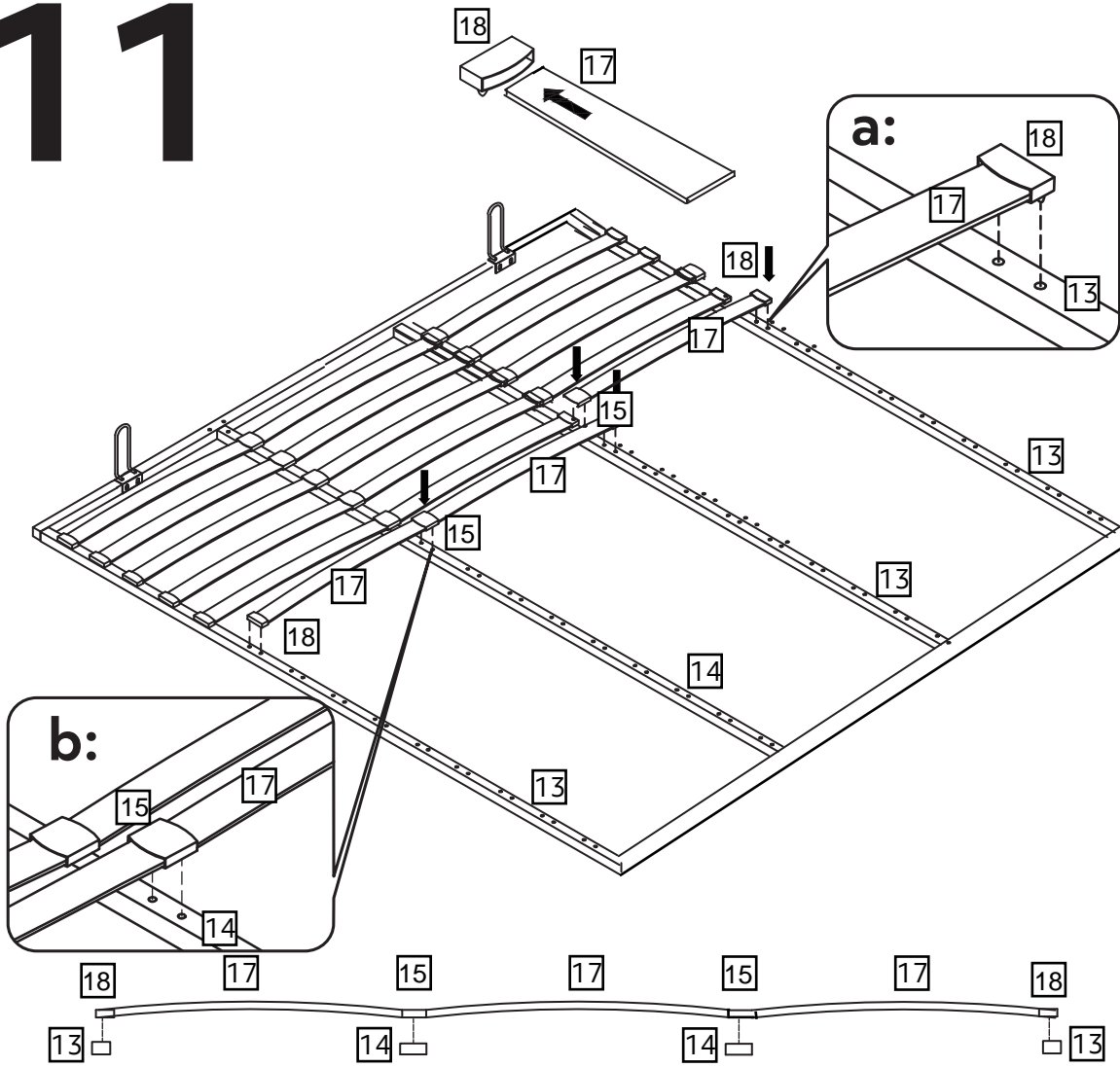

Slats to arch upwards
/Placer les lattes vers le haut

