

ASSEMBLY INSTRUCTIONS / NOTICE D'ASSEMBLAGE

ITEM: JYP-20814BLC/DENAWDSC
JYP-20815BLC/DENACDSC
JYP-20816BLC/DENAGDSC

Important note/Note importante:

1. Place all wooden parts on a clean and smooth surface such as a rug or carpet to avoid scratching the parts./ Placer les pièces sur une surface propre et lisse tel qu'une couverture ou un tapis pour éviter d'endommager les pièces.
2. Kindly follow the assembly instructions step by step./ Veuillez suivre la notice d'assemblage, pas à pas.
3. Do not tighten all screws and bolts until the chair is fully assembled./ Ne serrer les vis et boulons à fond que lorsque le produit est entièrement assemblé.

PARTS IDENTIFICATION / IDENTIFICATION DES PIÈCES

1 Chair Back
Dossier

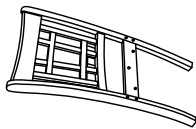

1pc

2 Wood Seat
Assise en Bois

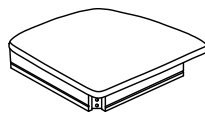

1pc

3 Front Leg
Pied Avant

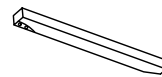

2pcs

HARDWARE IDENTIFICATION / IDENTIFICATION DES PIÈCES MONTAGE

A Bolt (Long)
Boulon (Long)

Ø1/4" x 20 x 3"



4pcs

B Bolt (Medium)
Boulon (Moyen)

Ø1/4" x 20 x 2-1/2"



4pcs

C Bolt (Short)
Boulon (Court)

Ø1/4" x 20 x 1-1/2"



3pcs

D Spring Washer
Rondelle D'arret

1/4" x Ø13 x 1.5mmT



11pcs

E Flat Washer
Rondelle Plate

1/4" x Ø19 x 2mmT



11pcs

F Allen Key
Clé Allen

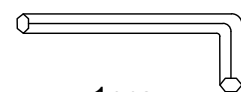

1pcs

ASSEMBLY INSTRUCTIONS / NOTICE D'ASSEMBLAGE

ITEM: JYP-20814BLC/DENAWDSC

JYP-20815BLC/DENACDSC

JYP-20816BLC/DENAGDSC

STEP 1 / ÉTAPE 1

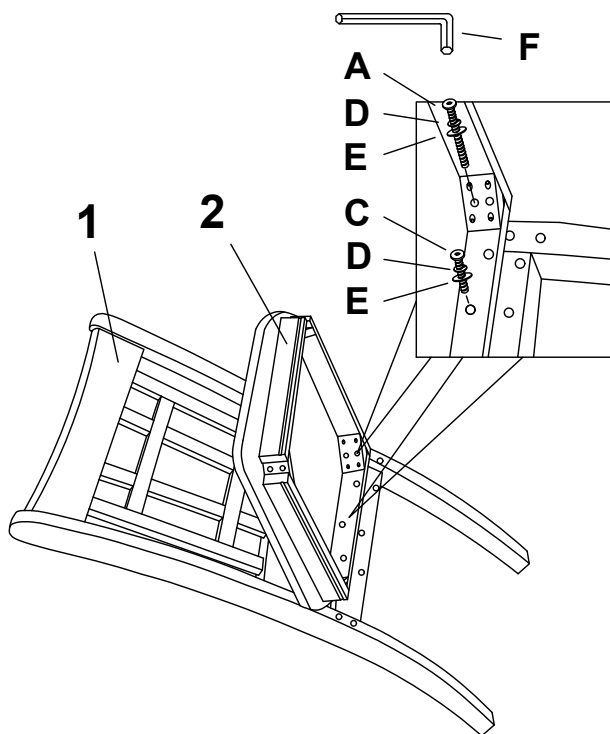

STEP 2 / ÉTAPE 2

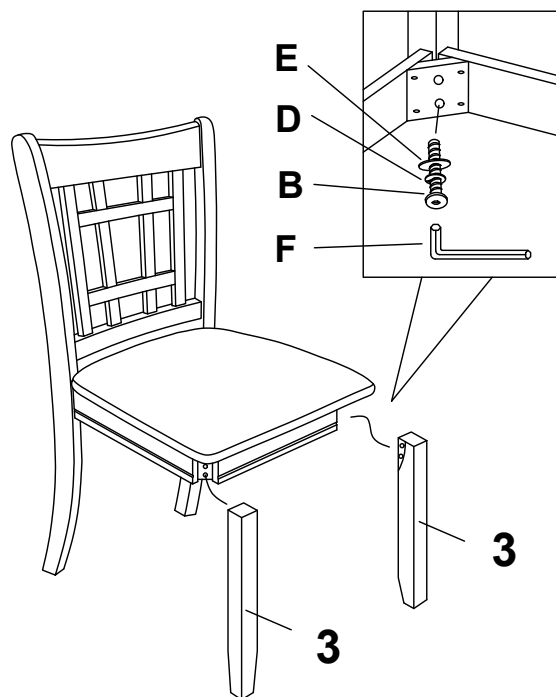

STEP 3 / ÉTAPE 3

