









ASSEMBLY INSTRUCTIONS (INSTRUCTIONS D'ASSEMBLAGE)

HARDWARE LIST (LISTE DES OUTILS):

NO.	Sketch	Description	Qty
NO.	Schéma	Description	Qté
1		Bolt(1/4"2-1/8") Boulon	2 PCS 2 PCES
2		Bolt(1/4"1-5/8") Boulon	4 PCS 4 PCES
3		Spring Washer(1/4") Rondelle frein	6 PCS 6 PCES
4		Washer(1/4") Rondelle plate	6PCS 6 PCES
5		Allen wrench(4mm) Clé hexagonale	1 PC 1 PCE

PARTS LIST (LISTE DES PIECES):

NO.	Sketch	Description	Qty
NO.	Schéma	Description	Qté
A		Seat Siège	1 PC 1 PCE
B		Back leg Pied arrière	1 PC 1 PCE
C		Front leg Pied avant	1 PC 1 PCE

Step 1 / Étape 1

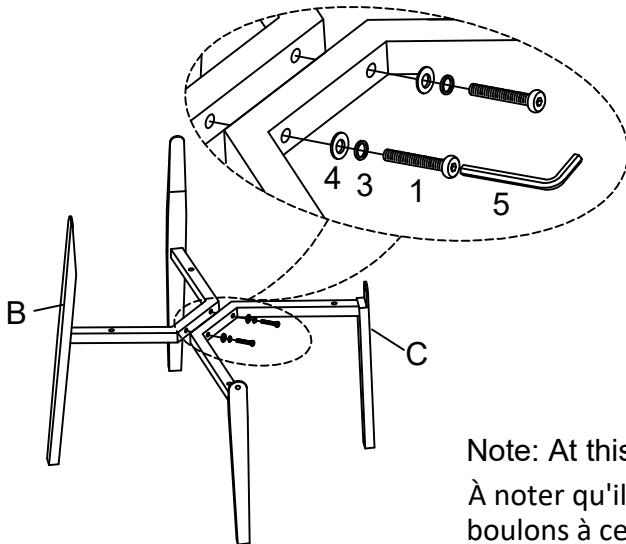

Note: At this stage, do not fully tighten the bolts .
 À noter qu'il ne faut pas serrer complètement les boulons à ce stade.

Step 2 / Étape 2

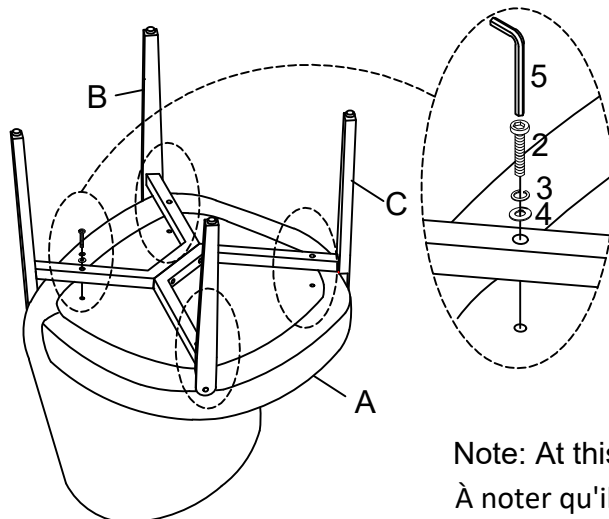

Note: At this stage, do not fully tighten the bolts .
 À noter qu'il ne faut pas serrer complètement les boulons à ce stade.

ASSEMBLY INSTRUCTIONS (INSTRUCTIONS D'ASSEMBLAGE)

Step 3 / Étape 3

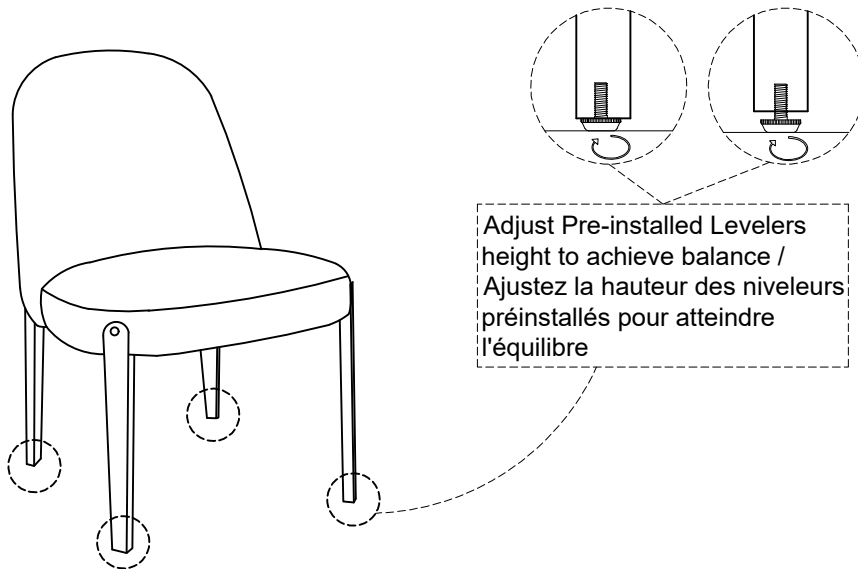

Adjust Pre-installed Levelers
height to achieve balance /
Ajustez la hauteur des niveleurs
préinstallés pour atteindre
l'équilibre

Note: Once the assembly is completed, proceed to tighten all bolts sequentially.

Note : Une fois l'assemblée complétée, serrez tous les boulons dans l'ordre consécutif.

Step 4 / Étape 4

