













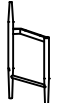

ASSEMBLY INSTRUCTIONS (INSTRUCTIONS D'ASSEMBLAGE)

HARDWARE LIST (LISTE DES OUTILS):

NO. NO.	Sketch Schéma	Description Description	Qty Qté
1		Bolt(5/32"x5/32") Boulon	4 PCS 4 PCES
2		Bolt(1/4"x2-1/8") Boulon	8 PCS 8 PCES
3		Bolt(1/4"x5/8") Boulon	8 PCS 8 PCES
4		Spring washer(1/4") Rondelle frein	12 PCS 12 PCES
5		Washer(1/4") Rondelle plate	12 PCS 12 PCS
6		Allen wrench(4mm) Clé hexagonale	1 PC 1 PCE
7		Allen wrench(2mm) Clé hexagonale	1 PC 1 PCE

PARTS LIST (LISTE DES PIÈCES):

NO. NO.	Sketch Schéma	Description Description	Qty Qté
A		Seat Siège	1 PC 1 PCE
B		Backrest Dossier	1 PC 1 PCE
C		Left metal leg frame Cadre de pied gauche en métal	1 PC 1 PCE
D		Right metal leg frame Cadre de pied droit en métal	1 PC 1 PCE
E		Back upper rail Traverses supérieures du dossier	1 PC 1 PCE
F		Front upper rail Traverses supérieures avant	1 PC 1 PCE
G		Back Bottom Rail Traverses inférieures du dossier	1 PC 1 PCE
H		Footrest Repose-pieds	1 PC 1 PCE

Step 1

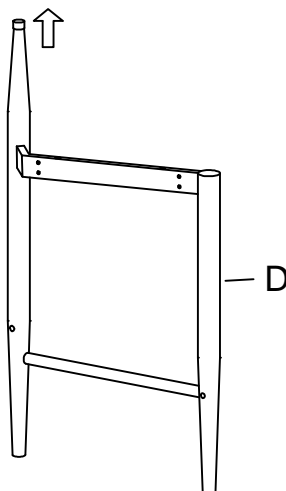
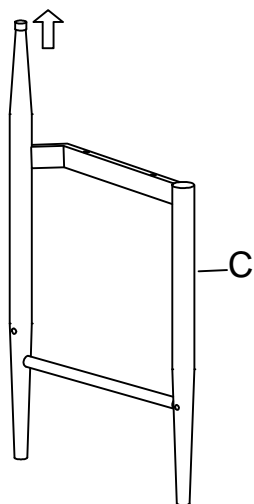

ASSEMBLY INSTRUCTIONS (INSTRUCTIONS D'ASSEMBLAGE)

Step 2

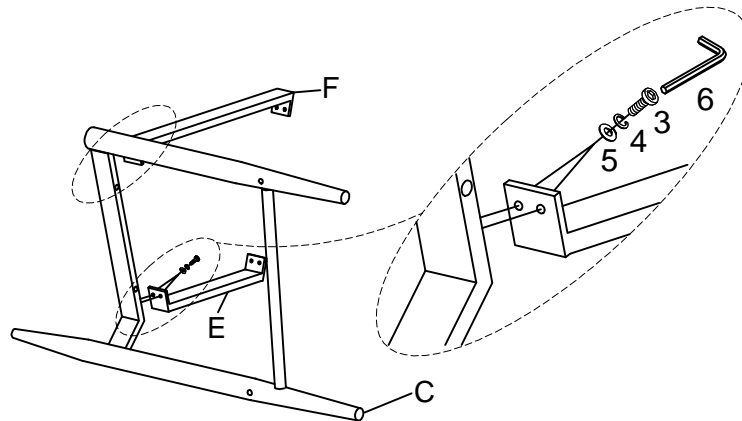

Note: At this stage, do not fully tighten the bolts .

À noter qu'il ne faut pas serrer complètement les boulons à ce stade.

Step 3

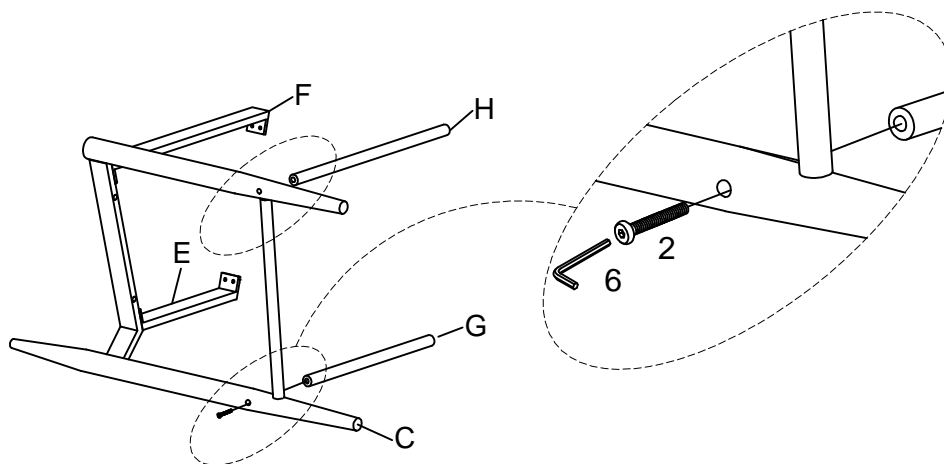

Note: At this stage, do not fully tighten the bolts .

À noter qu'il ne faut pas serrer complètement les boulons à ce stade.

ASSEMBLY INSTRUCTIONS (INSTRUCTIONS D'ASSEMBLAGE)

Step 4

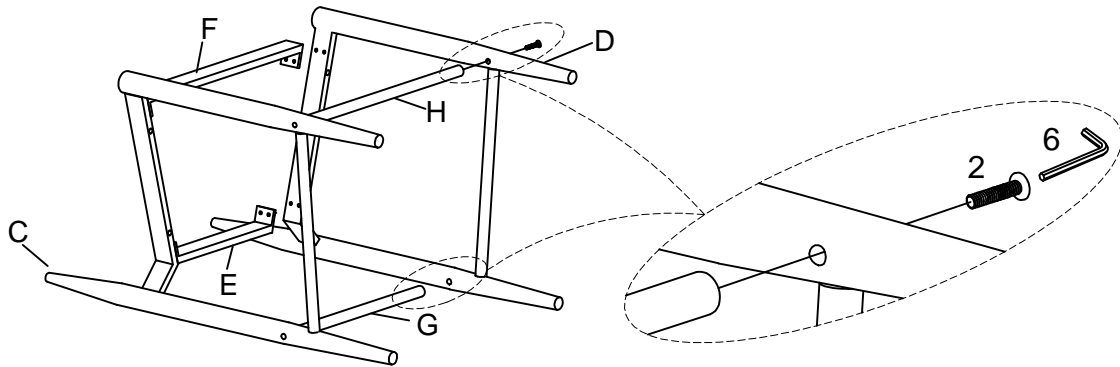

Note: At this stage, do not fully tighten the bolts .

À noter qu'il ne faut pas serrer complètement les boulons à ce stade.

Step 5

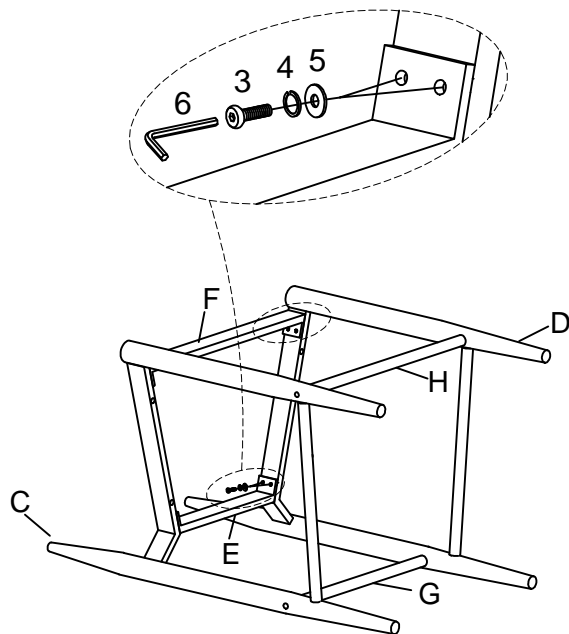

Note: At this stage, do not fully tighten the bolts .

À noter qu'il ne faut pas serrer complètement les boulons à ce stade.

Step 6

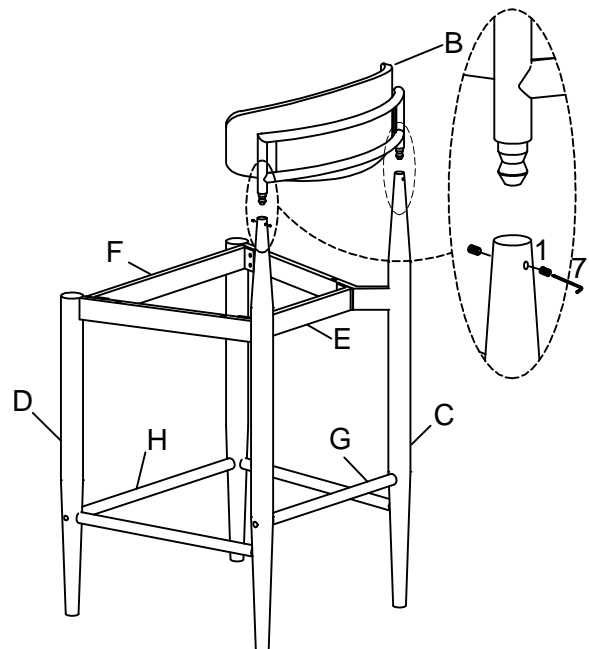

ASSEMBLY INSTRUCTIONS (INSTRUCTIONS D'ASSEMBLAGE)

Step 7

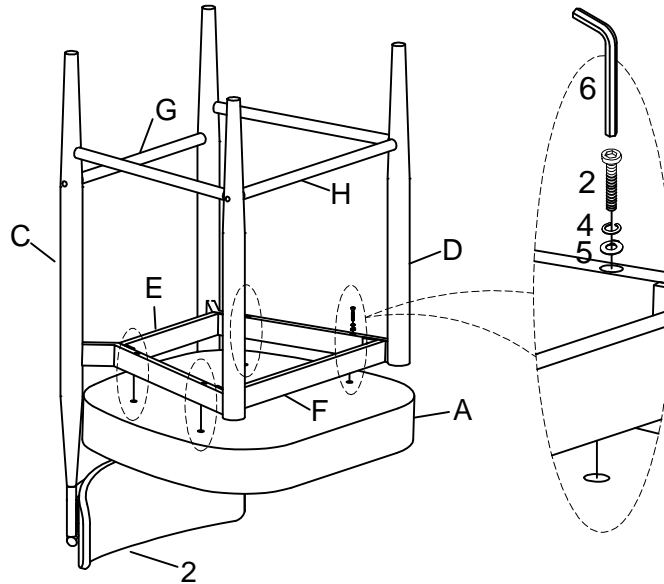

Note: Once the assembly is completed, proceed to tighten all bolts sequentially.

Note : Une fois l'assemblée complétée, serrez tous les boulons dans l'ordre consécutif.

Step 8

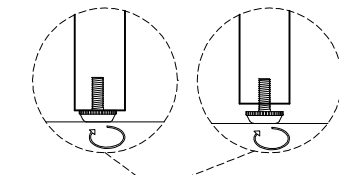
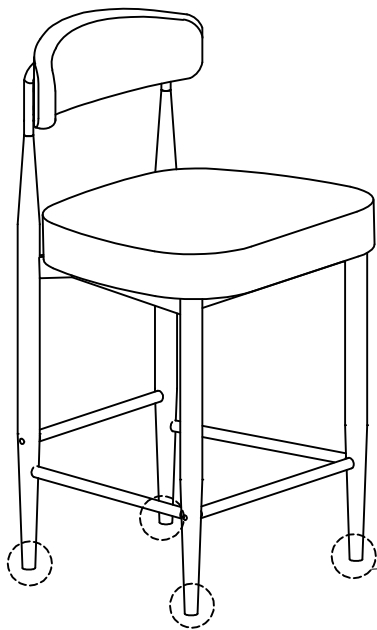

Adjust Pre-installed Levelers height to achieve balance /
Ajustez la hauteur des niveleurs préinstallés pour atteindre l'équilibre

Step 9

