









ASSEMBLY INSTRUCTIONS (INSTRUCTIONS D'ASSEMBLAGE)

HARDWARE LIST (LISTE DES OUTILS):

NO. NO.	Sketch Schéma	Description Description	Qty Qté
1		Bolt(5/32" x 5/32") Boulon	4 PCS 4 PCES
2		Bolt(1/4" x 2-1/8") Boulon	4 PCS 4 PCES
3		Spring Washer(1/4") Rondelle frein	4 PCS 4 PCES
4		Washer(1/4") Rondelle plate	4 PCS 4 PCES
5		Allen Wrench(4mm) Clé hexagonale	1 PC 1 PCE
6		Allen Wrench(2mm) Clé hexagonale	1 PC 1 PCE

PARTS LIST (LISTE DES PIECES):

NO. NO.	Sketch Schéma	Description Description	Qty Qté
A		Seat Siège	1 PC 1 PCE
B		Backrest Dossier	1 PC 1 PCE
C		Metal frame Cadre en métal	1 PC 1 PCE

Step 1 / Étape 1

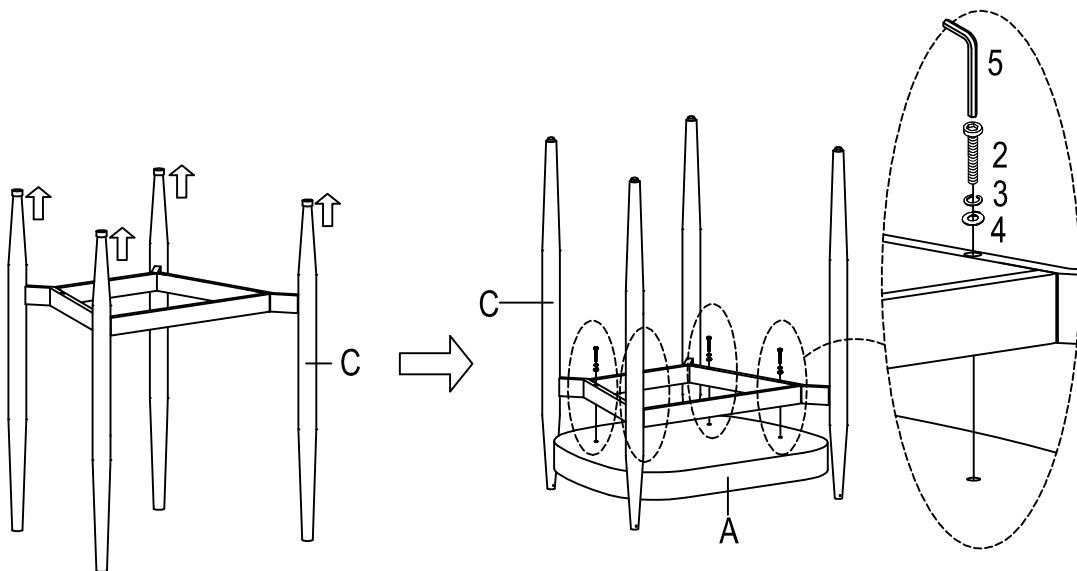

ASSEMBLY INSTRUCTIONS (INSTRUCTIONS D'ASSEMBLAGE)

Step 2 / Étape 2

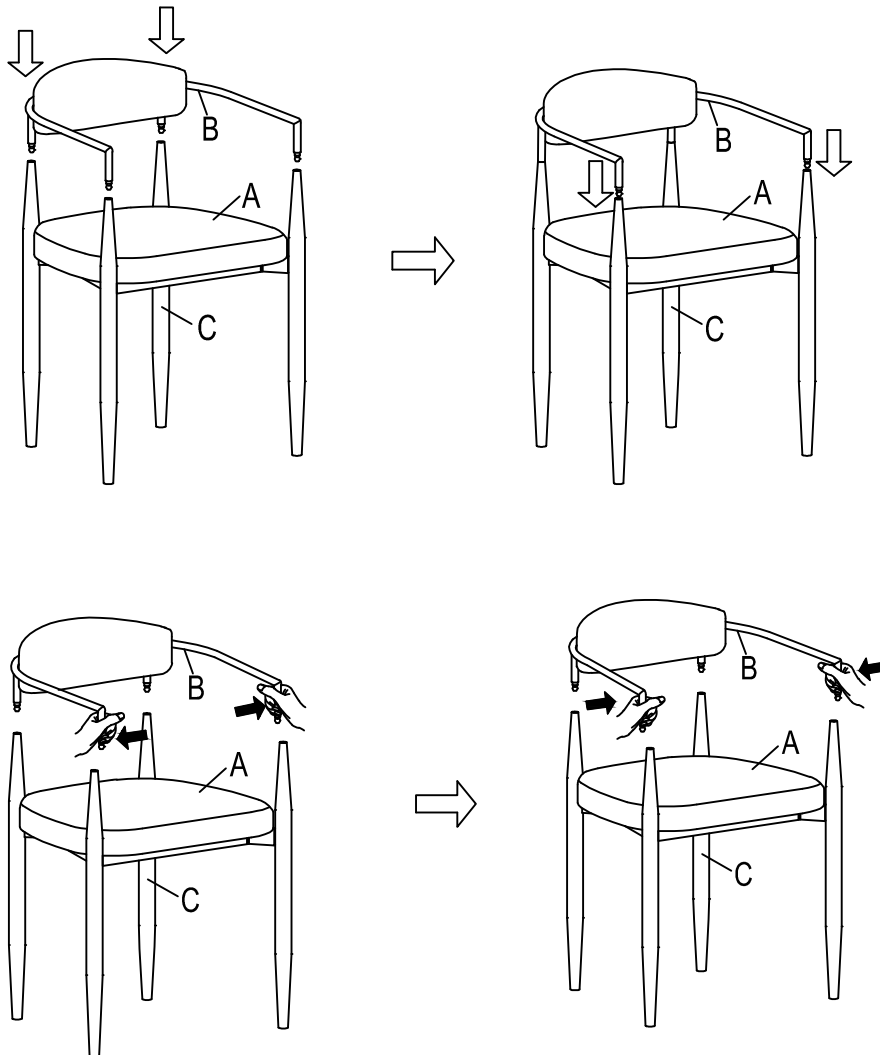

Note: If the metal tube on both sides of the armrest of the Chair Back(B) is not aligned with the holes on the Leg Frame(C), please gently use your hand to force them inward or outward to align and insert them.

Note : Si le tube métallique des deux côtés de l'accoudoir du dossier (B) n'est pas aligné avec les trous sur le cadre des pieds (C), poussez-le doucement vers l'intérieur ou vers l'extérieur pour les aligner et les insérer.

ASSEMBLY INSTRUCTIONS (INSTRUCTIONS D'ASSEMBLAGE)

Step 3 / Étape 3

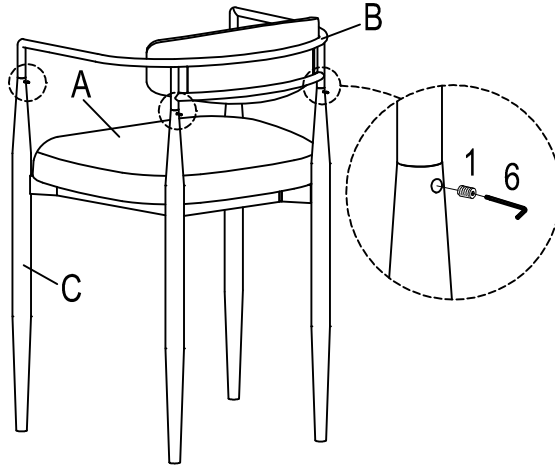

Step 4 / Étape 4

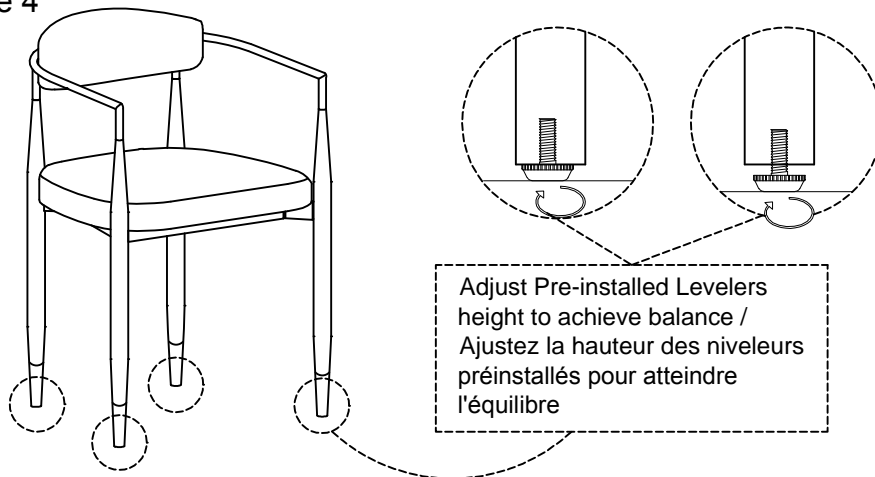

Step 5 / Étape 5

