











ASSEMBLY INSTRUCTIONS (INSTRUCTIONS D'ASSEMBLAGE)

HARDWARE LIST (LISTE DES OUTILS):

NO.	Sketch	Description	Qty
NO.	Schéma	Description	Qté
A		Bolt(1/4"*5/8") Boulon	9 PCS 9 PCES
B		Spring Washer(1/4") Rondelle frein	9 PCS 9 PCES
C		Washer(1/4") Rondelle plate	9 PCS 9 PCES
D		Pad Pad	6 PCS 6 PCES
E		Allen wrench(4mm) Clé hexagonale	1 PC 1 PCE
F		Screw (Ø4*12mm) Vis	16 PC 16 PCE

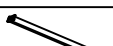
PARTS LIST (LISTE DES PIÈCES):

NO.	Sketch	Description	Qty
NO.	Schéma	Description	Qté
1		Glass Top Vitre de table	1 PC 1 PCE
2		Top Frame Cadre supérieur	1 PC 1 PCE
3		Shelf Étagère	1 PC 1 PCE
4		Leg Pied	3 PCS 3 PCES
5		Wheel Roue	4 PCS 4 PCES

Step 1 / Étape 1

CADRE SUPÉRIEUR

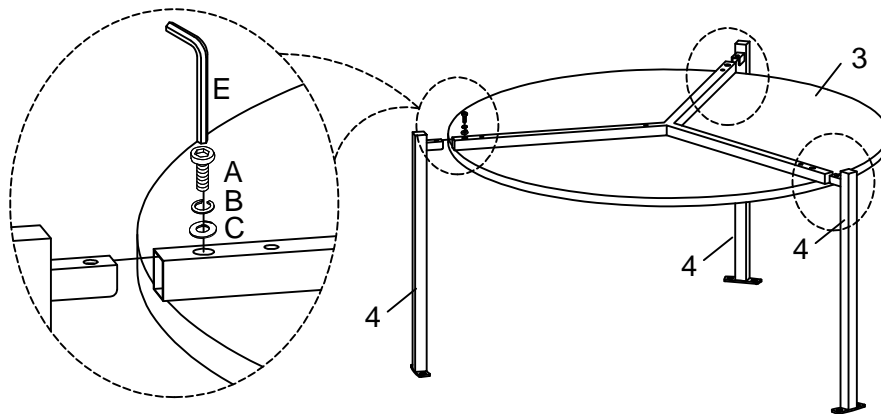

Note: At this stage, do not fully tighten the bolts .

À noter qu'il ne faut pas serrer complètement les boulons à ce stade.

Step 2 / Étape 2

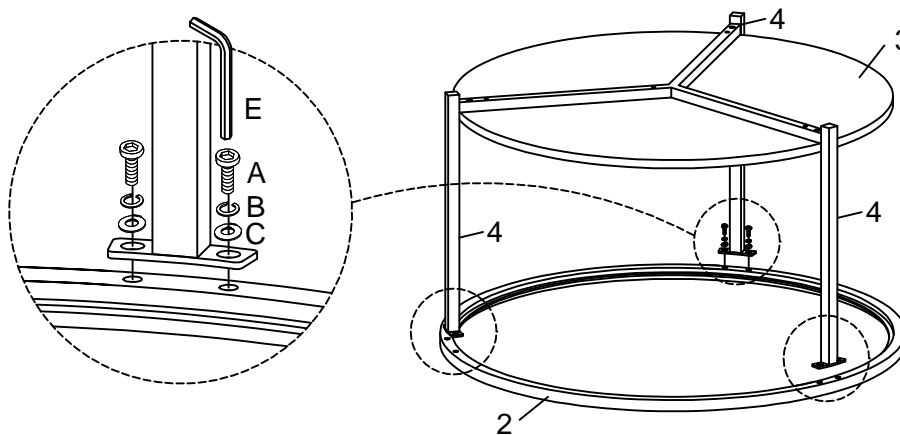

Note: At this stage, do not fully tighten the bolts .

À noter qu'il ne faut pas serrer complètement les boulons à ce stade.

ASSEMBLY INSTRUCTIONS (INSTRUCTIONS D'ASSEMBLAGE)

Step 3 / Étape 3

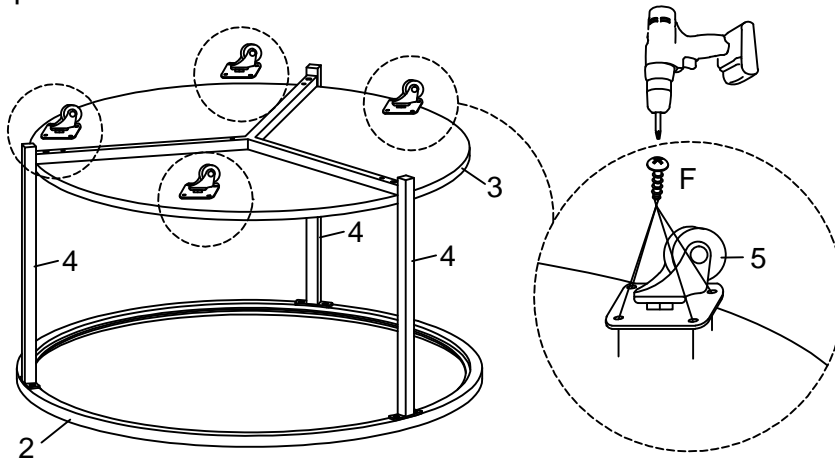

Note: At this stage, tighten all Bolts at all joints fully in a sequential manner.

À noter qu'il faut s'assurer de serrer complètement les boulons de manière séquentielle à ce stade

Step 4 / Étape 4

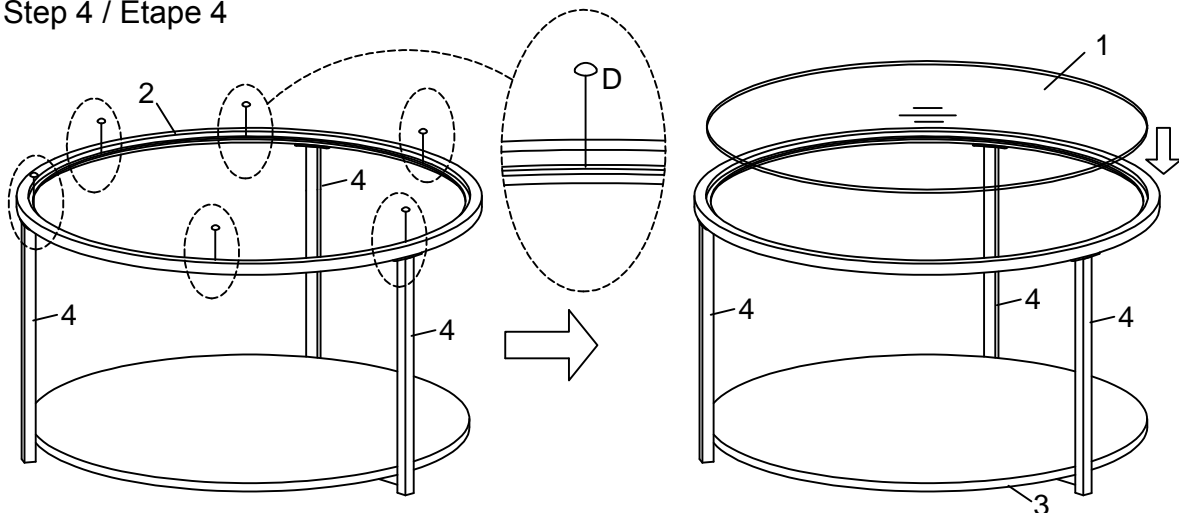

Step 5 / Étape 5

